



BeagleBone Black



Table of contents

1	Introduction	3
2	Change History	5
2.1	Document Change History	5
2.2	Board Changes	6
2.2.1	Rev C3a	6
2.2.2	Rev C3	6
2.2.3	Rev C2	7
2.2.4	Rev C1	7
2.2.5	Rev C	7
2.2.6	Rev B	7
2.2.7	Rev A6A	7
2.2.8	Rev A6	8
2.2.9	Rev A5C	8
2.2.10	Rev A5B	8
2.2.11	Rev A5A	8
3	Connecting Up Your BeagleBone Black	9
3.1	What's In the Box	9
3.2	Main Connection Scenarios	10
3.2.1	Tethered To A PC	10
3.2.2	Standalone w/Display and Keyboard/Mouse	12
4	BeagleBone Black Overview	19
4.1	BeagleBone Compatibility	19
4.2	BeagleBone Black Features and Specification	20
4.3	Board Component Locations	21
4.3.1	Connectors, LEDs, and Switches	21
4.3.2	Key Components	22
5	BeagleBone Black High Level Specification	25
5.1	Block Diagram	25
5.2	Processor	26
5.3	Memory	26
5.3.1	512MB DDR3L	26
5.3.2	4KB EEPROM	26
5.3.3	4GB Embedded MMC	26
5.3.4	MicroSD Connector	26
5.3.5	Boot Modes	26
5.4	Power Management	27
5.4.1	PC USB Interface	27
5.4.2	Serial Debug Port	27
5.4.3	USB1 Host Port	27
5.4.4	Power Sources	28
5.4.5	Reset Button	28
5.4.6	Power Button	28
5.4.7	Indicators	28
5.4.8	CTI JTAG Header	29

5.4.9	HDMI Interface	29
5.4.10	Cape Board Support	29
6	Detailed Hardware Design	31
6.1	Power Section	31
6.1.1	TPS65217C PMIC	32
6.1.2	DC Input	32
6.1.3	USB Power	34
6.1.4	Power Selection	34
6.1.5	Power Button	34
6.1.6	Battery Access Pads	36
6.1.7	Power Consumption	36
6.1.8	Processor Interfaces	37
6.1.9	Power Rails	37
6.1.10	Power LED	39
6.1.11	TPS65217C Power Up Process	40
6.1.12	Processor Control Interface	40
6.1.13	Low Power Mode Support	41
6.2	Sitara AM3358BZCZ100 Processor	41
6.2.1	Description	41
6.2.2	High Level Features	41
6.2.3	Documentation	42
6.2.4	Crystal Circuitry	42
6.2.5	Reset Circuitry	42
6.2.6	Memory Device	42
6.2.7	DDR3L Memory Design	44
6.2.8	Power Rails	46
6.2.9	VREF	46
6.2.10	4GB eMMC Memory	46
6.2.11	eMMC Device	47
6.2.12	eMMC Circuit Design	47
6.2.13	Board ID EEPROM	48
6.2.14	microSD Design	49
6.3	6.6 User LEDs	49
6.3.1	Boot Configuration	50
6.3.2	Boot Configuration Design	50
6.3.3	Default Boot Options	50
6.4	10/100 Ethernet	52
6.4.1	Ethernet Processor Interface	52
6.4.2	Ethernet Connector Interface	52
6.4.3	Ethernet PHY Power, Reset, and Clocks	52
6.5	LAN8710A Mode Pins	54
6.6	HDMI Interface	54
6.6.1	Supported Resolutions	55
6.6.2	HDMI Framer	55
6.6.3	HDMI Video Processor Interface	55
6.6.4	HDMI Control Processor Interface	57
6.6.5	Interrupt Signal	57
6.6.6	Audio Interface	57
6.6.7	Power Connections	58
6.6.8	HDMI Connector Interface	58
6.7	USB Host	58
6.7.1	Power Switch	58
6.7.2	ESD Protection	58
6.7.3	Filter Options	60
6.8	PRU-ICSS	60
6.8.1	PRU-ICSS Features	60
6.8.2	PRU-ICSS Block Diagram	60

6.8.3	PRU-ICSS Pin Access	60
7	Connectors	65
7.1	Expansion Connectors	65
7.1.1	Connector P8	65
7.1.2	Connector P9	68
7.2	Power Jack	70
7.3	USB Client	70
7.4	USB Host	70
7.5	Serial Header	72
7.6	HDMI	73
7.7	microSD	73
7.8	Ethernet	76
7.9	JTAG Connector	76
8	Cape Board Support	77
8.1	BeagleBone Black Cape Compatibility	77
8.1.1	LCD Pins	77
8.1.2	eMMC Pins	78
8.1.3	EEPROM	79
8.1.4	EEPROM Address	80
8.1.5	I2C Bus	80
8.1.6	EEPROM Data Format	81
8.1.7	Pin Usage	81
8.2	Pin Usage Consideration	85
8.2.1	Boot PIN	85
8.2.2	Expansion Connectors	86
8.2.3	Non-Stacking Headers-Single Cape	86
8.2.4	Main Expansion Headers-Stacking	87
8.2.5	StackedStealing	87
8.2.6	Retention Force	88
8.3	Signal Usage	89
8.4	Cape Power	89
8.4.1	Main Board Power	89
8.4.2	Power	89
8.5	Mechanical	90
8.5.1	Standard Cape Size	90
8.5.2	Extended Cape Size	91
8.5.3	Enclosures	91
9	BeagleBone Black Mechanical	93
9.1	Dimensions and Weight	93
9.2	Silkscreen and Component Locations	93
10	Pictures	97
11	Support Information	101
11.1	Hardware Design	101
11.2	Software Updates	101
11.3	Production board boot media	101
11.4	RMA Support	102
11.5	Trouble Shooting HDMI Issues	102
11.5.1	EDID	103
11.5.2	DISPLAY SOURCE SELECTION	103
11.5.3	OUT OF SEQUENCE	103
11.5.4	OVERSCAN	104
11.5.5	Taking a Nap	104
11.5.6	AUDIO	104
11.5.7	Getting Help	104

BeagleBone Black is a low-cost, community-supported development platform for developers and hobbyists. Boot Linux in under 10 seconds and get started on development in less than 5 minutes with just a single USB cable.

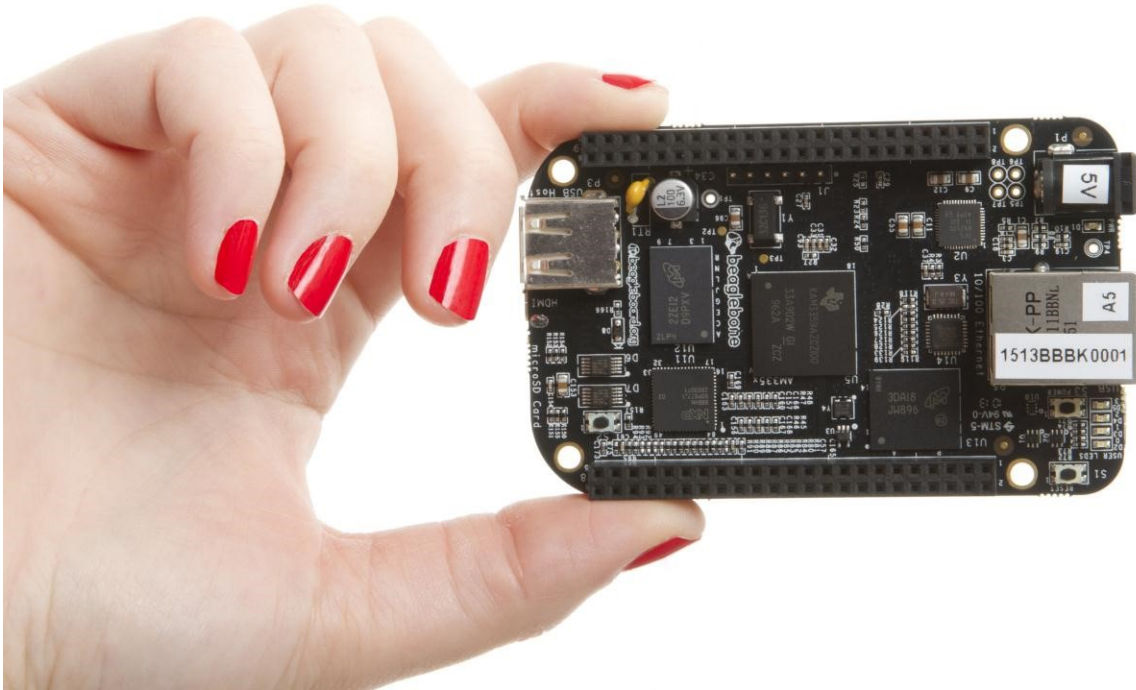

Chapter 1

Introduction

This document is the *System Reference Manual* for the BeagleBone Black and covers its use and design. The board will primarily be referred to in the remainder of this document simply as the board, although it may also be referred to as the BeagleBone Black as a reminder. There are also references to the original BeagleBone as well, and will be referenced as simply BeagleBone.

This design is subject to change without notice as we will work to keep improving the design as the product matures based on feedback and experience. Software updates will be frequent and will be independent of the hardware revisions and as such not result in a change in the revision number.

Make sure you check the docs repository frequently for the most up to date information.

<https://git.beagleboard.org/docs/docs.beagleboard.io/-/tree/main/beaglebone-black>

Chapter 2

Change History

This section describes the change history of this document and board. Document changes are not always a result of a board change. A board change will always result in a document change.

2.1 Document Change History

Table 2.1: AsciiDoc Change History

Rev	Changes	Date	By
A4	Preliminary	January 4, 2013	GC
A5	Production release	January 8, 2013	GC
A5.1	<ol style="list-style-type: none">1. Added information on Power button and the battery access points.2. Final production released version.	April 1 2013	GC
A5.2	<ol style="list-style-type: none">1. Edited version.2. Added numerous pictures of the Rev A5A board.	April 23 2013	GC
A5.3	<ol style="list-style-type: none">1. Updated serial number locations.2. Corrected the feature table for 4 UARTS3. Corrected eMMC pin table to match other tables in the manual.	April 30, 2013	GC
A5.4	<ol style="list-style-type: none">1. Corrected revision listed in section 2. Rev A5A is the initial production release.2. Added all the locations of the serial numbers3. Made additions to the compatibility list.4. Corrected «table-7» for LED GPIO pins.5. Fixed several typos.6. Added some additional information about LDOs and Step-Down converters.7. Added short section on HDMI.	May 12, 2013	GC

continues on next page

Table 2.1 – continued from previous page

Rev	Changes	Date	By
A5.5	<ol style="list-style-type: none"> 1. Release of the A5B version. 2. The LEDs were dimmed by changing the resistors. 3. The serial termination mode was incorporated into the PCB. 	May 20, 2013	GC
A5.6	<ol style="list-style-type: none"> 1. Added information on Rev A5C 2. Added PRU/ICSS options to tables for P8 and P9. 3. Added section on USB Host Correct modes on «table-15». 4. Fixed a few typos 	June 16, 2013	GC
A5.7	<ol style="list-style-type: none"> 1. Updated assembly revision to A6. 2. PCB change to add buffer to the reset line and ground the oscillator GND pin. 3. Added resistor on PCB for connection of OSC_GND to board GND. 	August 9, 2013	GC
A6	<ol style="list-style-type: none"> 1. Added Rev A6 changes. 	October 11, 2013	GC
A6A	<ol style="list-style-type: none"> 1. Added Rev A6A changes 	December 17, 2013	GC
B	<ol style="list-style-type: none"> 1. Changed the processor to the AM3358BZCZ 	January 20, 2013	GC
C	<ol style="list-style-type: none"> 1. Changed the eMMC from 2GB to 4GB. 2. Added additional supplier to DDR2 and eMMC. 	March 21, 2014	GC
C.1	<ol style="list-style-type: none"> 1. Added note to recommend powering off the board with the power 	March 22, 2014	GC
C.2	Numerous community edits and format changes to asciidoc.	May 6, 2020	JK
C.3	Added information for board rev C3.	August 24, 2021	JK

2.2 Board Changes

2.2.1 Rev C3a

PCB revision C.

- New USB Type-A connector.

2.2.2 Rev C3

PCB revision C.

- Updated microSD card cage due to availability. See <https://git.beagleboard.org/beagleboard/beaglebone-black/-/issues/6>. Added series resistors and depopulated C5.

- Added reset option (GPIO1_8) for Ethernet PHY to avoid possible start-up issue. See <https://git.beagleboard.org/beagleboard/beaglebone-black/-/issues/4>.
- Added series resistors to MMC1 lines and depopulated C24.
- Connected pin A6 of J5 on U13 (eMMC IC) to DGND.
- Changed USB1_VBUS series resistor to 0 ohm.
- Change required PCB revision to C.

Initial boxes mistakenly say rev C1.

2.2.3 Rev C2

PCB revision B6.

- Update memories based on availability. See <https://github.com/beagleboard/beaglebone-black/commit/74914bd01efeb61376ec3dda4bf9143ad2bb635c>.
 - DDR3:
 - * Kingston D2516EC4BXGGB-U
 - eMMC:
 - * Kingston MMC04G-M627-X02U

2.2.4 Rev C1

PCB revision B6.

- Update memories based on availability. See <https://github.com/beagleboard/beaglebone-black/commit/5787736d816832cc8cc9629d19f334b6a12e67f9>.
 - DDR3:
 - * Micron MT41K256M16TW-107:P
 - eMMC:
 - * Micron MTFC4GACAJCN-1M WT
 - * Kingston EMMC04G-S100-A08U

2.2.5 Rev C

- Changed the eMMC from 2GB to 4GB.

2GB devices are getting harder to get as they are being phased out. This required us to move to 4GB. We now have two sources for the device. This will however, require an increase in the price of the board.

2.2.6 Rev B

- Changed the processor to the AM3358BZCZ100.

2.2.7 Rev A6A

- Added connection from 32KHz OSC_GND to system ground and changed C106 to 1uF.
- Changes C25 to 2.2uF. This resolved an issue we were seeing in a few boards where the board would not boot in 1 in 20 tries.

- Change required PCB revision to B6.

2.2.8 Rev A6

- In random instances there could be a glitch in the SYS_RESETh signal from the processor where the SYS_RESETh signal was taken high for a momentary amount of time before it was supposed to. To prevent this, the signal was ORed with the PORZn (Power On reset).
- Noise issues were observed in other design where the clock oscillator was getting hit due to a suspected issue in ground bounce. A zero ohm resistor was added to connect the OSC_GND to the system ground.

There are no new features added as a result of these changes.

2.2.9 Rev A5C

We were seeing some fallout in production test where we were seeing some jitter on the HDMI display test. It started showing up on our second production run. R46, R47, R48 were changed to 0 ohm from 33 ohm. R45 was taken from 330 ohm to 22 ohm.

We do not know of any boards that were shipped with this issue as this issue was caught in production test. No impact on features or functionality resulted from this change.

2.2.10 Rev A5B

There is no operational difference between the Rev A5A and the Rev A5B. There were two changes made to the A5B version.

- Due to complaints about the brightness of the LEDs keeping people awake at night, the LEDs were dimmed. Resistors were changed from 820 ohms to 4.75K ohms.
- The PCB revision was updated to incorporate the hand mod that was being done on the board during manufacturing. The resistor was incorporated into the next revision of the PCB.

The highest supported resolution is now listed as 1920x1080@24Hz. This was not a result of any hardware changes but only updated software. The A5A version also supports this resolution.

2.2.11 Rev A5A

This is the initial production release of the board. We will be tracking changes from this point forward.

Chapter 3

Connecting Up Your BeagleBone Black

This section provides instructions on how to hook up your board. Two scenarios will be discussed:

1. Tethered to a PC and
2. As a standalone development platform in a desktop PC configuration.

3.1 What's In the Box

In the box you will find three main items as shown in «figure-1».

- BeagleBone Black
- miniUSB to USB Type A Cable
- Instruction card with link to the support WIKI address.

This is sufficient for the tethered scenario and creates an out of box experience where the board can be used immediately with no other equipment needed.



Fig. 3.1: In the Box

3.2 Main Connection Scenarios

This section will describe how to connect the board for use. This section is basically a slightly more detailed description of the Quick Start Guide that came in the box. There is also a Quick Start Guide document on the board that should also be referred to. The intent here is that someone looking to purchase the board will be able to read this section and get a good idea as to what the initial set up will be like.

The board can be configured in several different ways, but we will discuss the two most common scenarios as described in the Quick Start Guide card that comes in the box.

- Tethered to a PC via the USB cable
 - Board is accessed as a storage drive
 - Or a RNDIS Ethernet connection.
- Standalone desktop
 - Display
 - Keyboard and mouse
 - External 5V power supply

Each of these configurations is discussed in general terms in the following sections.

For an up-to-date list of confirmed working accessories please go to [BeagleBone_Black_Accessories](#)

3.2.1 Tethered To A PC

In this configuration, the board is powered by the PC via the provided USB cable-no other cables are required. The board is accessed either as a USB storage drive or via the browser on the PC. You need to use either Firefox or Chrome on the PC, Internet Explorer will not work properly. «figure-2» shows this configuration.

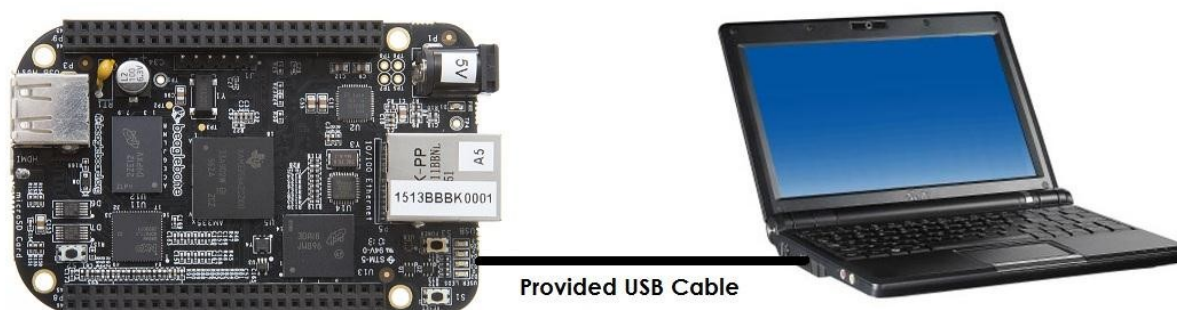

Fig. 3.2: Tethered Configuration

All the power for the board is provided by the PC via the USB cable. In some instances, the PC may not be able to supply sufficient power for the board. In that case, an external 5VDC power supply can be used, but this should rarely be necessary.

Connect the Cable to the Board

1. Connect the small connector on the USB cable to the board as shown in *figure-3*. The connector is on the bottom side of the board.
2. Connect the large connector of the USB cable to your PC or laptop USB port.
3. The board will power on and the power LED will be on as shown in figure below.

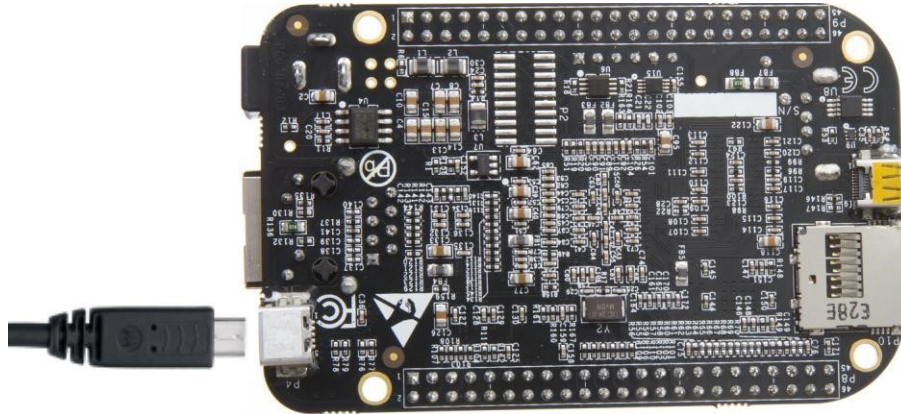

Fig. 3.3: USB Connection to the Board

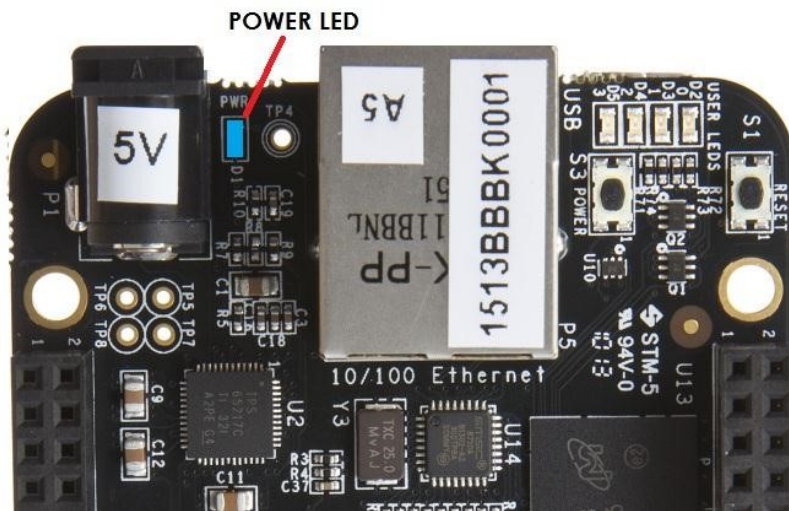

Fig. 3.4: Board Power LED

- When the board starts to the booting process started by the process of applying power, the LEDs will come on in sequence as shown in *figure-5* below. It will take a few seconds for the status LEDs to come on, so be patient. The LEDs will be flashing in an erratic manner as it begins to boot the Linux kernel.

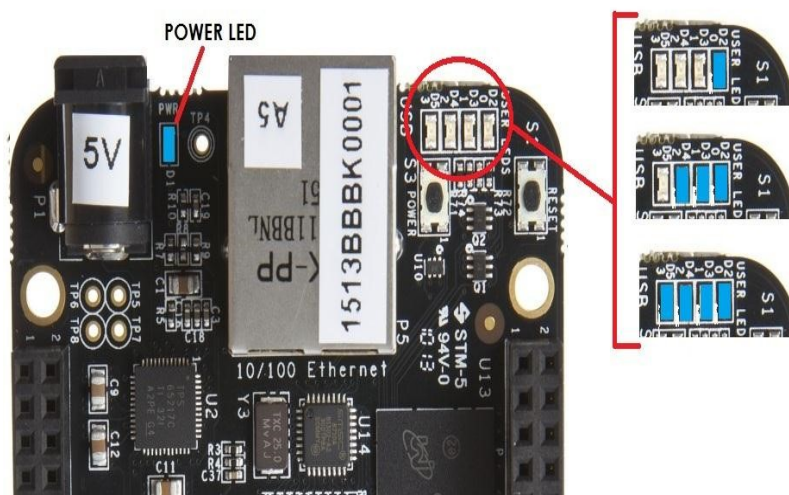

Fig. 3.5: Board Boot Status

Accessing the Board as a Storage Drive

The board will appear around a USB Storage drive on your PC after the kernel has booted, which will take around 10 seconds. The kernel on the board needs to boot before the port gets enumerated. Once the board appears as a storage drive, do the following:

- Open the USB Drive folder.
- Click on the file named *start.htm*
- The file will be opened by your browser on the PC and you should get a display showing the Quick Start Guide.
- Your board is now operational! Follow the instructions on your PC screen.

3.2.2 Standalone w/Display and Keyboard/Mouse

In this configuration, the board works more like a PC, totally free from any connection to a PC as shown in «figure-6». It allows you to create your code to make the board do whatever you need it to do. It will however require certain common PC accessories. These accessories and instructions are described in the following section.

Optionally an Ethernet cable can also be used for network access.

Required Accessories

In order to use the board in this configuration, you will need the following accessories:

- 1 x 5VDC 1A power supply
- 1 x HDMI monitor or a DVI-D monitor. (NOTE: Only HDMI will give you audio capability).
- 1 x Micro HDMI to HDMI cable or a Micro HDMI to DVI-D adapter.
- 1 x USB wireless keyboard and mouse combo.

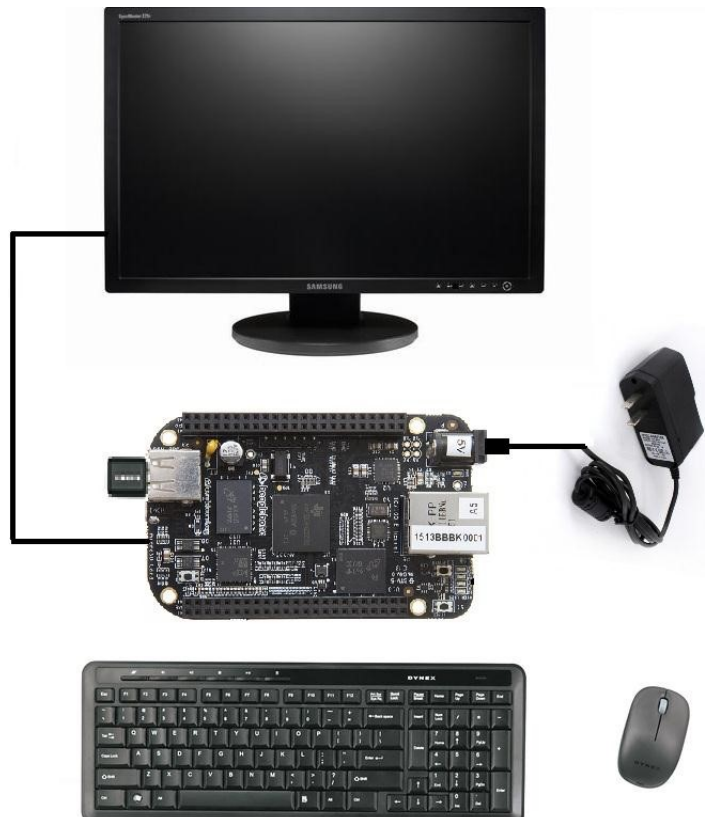

Fig. 3.6: Desktop Configuration

- 1 x USB HUB (OPTIONAL). The board has only one USB host port, so you may need to use a USB Hub if your keyboard and mouse requires two ports.

For an up-to-date list of confirmed working accessories please go to [BeagleBone_Black_Accessories](#)

Connecting Up the Board

1. Connect the big end of the HDMI cable as shown in *figure-7* to your HDMI monitor. Refer to your monitor Owner's Manual for the location of your HDMI port. If you have a DVI-D Monitor go to *Step 3*, otherwise proceed to *Step 4*.



Fig. 3.7: Connect microHDMI Cable to the Monitor

2. If you have a DVI-D monitor you must use a DVI-D to HDMI adapter in addition to your HDMI cable. An example is shown in *figure-8* below from two perspectives. If you use this configuration, you will not have audio support.
3. If you have a single wireless keyboard and mouse combination such as seen in *figure-9* below, you need to plug the receiver in the USB host port of the board as shown in *figure-10*.

If you have a wired USB keyboard requiring two USB ports, you will need a HUB similar to the ones shown in figure below. You may want to have more than one port for other devices. Note that the board can only supply up to 500mA, so if you plan to load it down, it will need to be externally powered.



Fig. 3.8: DVI-D to HDMI Adapter



Fig. 3.9: Wireless Keyboard and Mouse Combo

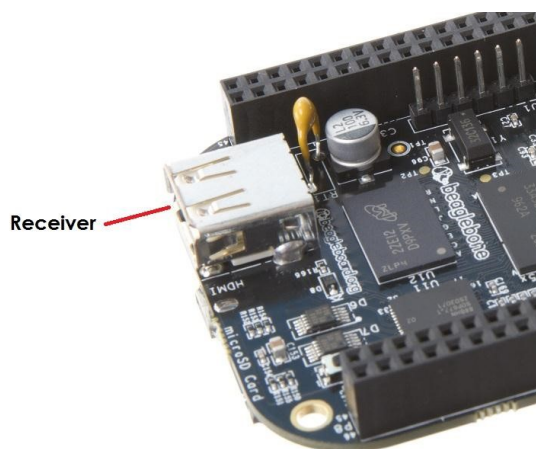

Fig. 3.10: Connect Keyboard and Mouse Receiver to the Board



Fig. 3.11: Keyboard and Mouse Hubs

4. Connect the Ethernet Cable

If you decide you want to connect to your local area network, an Ethernet cable can be used. Connect the Ethernet Cable to the Ethernet port as shown in figure below . Any standard 100M Ethernet cable should work.

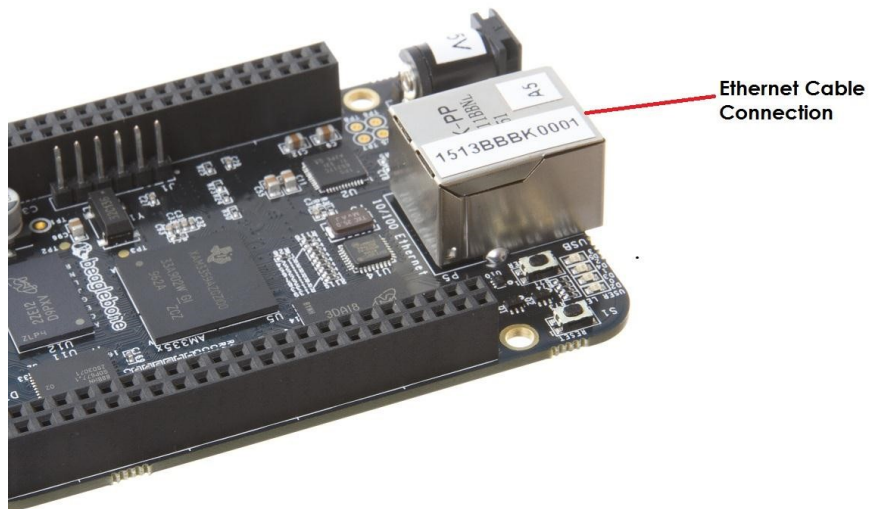

Fig. 3.12: Ethernet Cable Connection

5. The final step is to plug in the DC power supply to the DC power jack as shown in figure below.

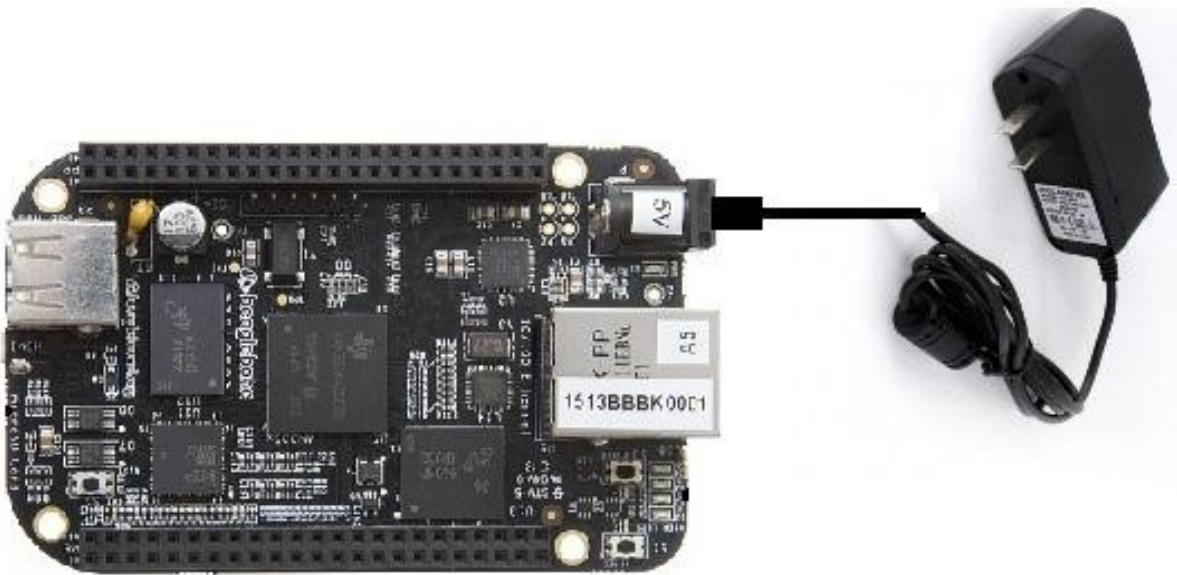

Fig. 3.13: External DC Power

6. The cable needed to connect to your display is a microHDMI to HDMI. Connect the microHDMI connector end to the board at this time. The connector is on the bottom side of the board as shown in *figure-14* below.

The connector is fairly robust, but we suggest that you not use the cable as a leash for your Beagle. Take proper care not to put too much stress on the connector or cable.

7. Booting the Board

As soon as the power is applied to the board, it will start the booting up process. When the board starts to boot the LEDs will come on in sequence as shown in *figure-15* below. It will take a few seconds for the status LEDs to come on, so be patient. The LEDs will be flashing in an erratic manner as it boots the Linux kernel.

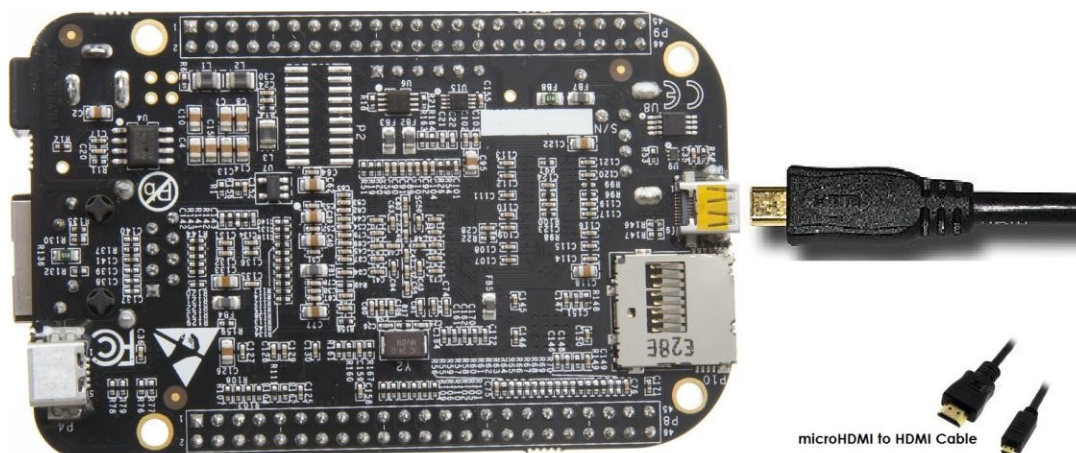

Fig. 3.14: Connect microHDMI Cable to the Board

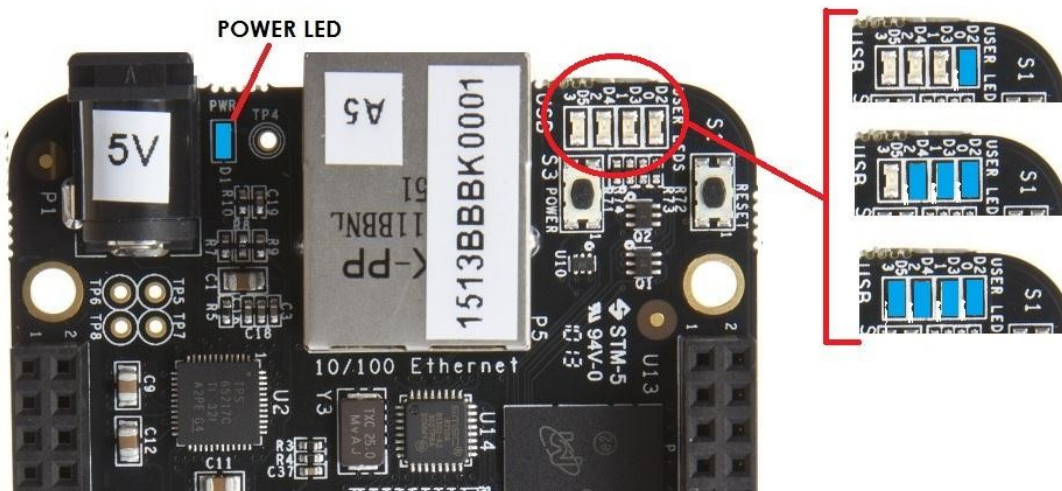

Fig. 3.15: Board Boot Status

While the four user LEDs can be overwritten and used as desired, they do have specific meanings in the image that is shipped with the board once the Linux kernel has booted.

- *USER0* is the heartbeat indicator from the Linux kernel.
- *USER1* turns on when the microSD card is being accessed
- *USER2* is an activity indicator. It turns on when the kernel is not in the idle loop.
- *USER3* turns on when the onboard eMMC is being accessed.

8. A Booted System

- a. The board will have a mouse pointer appear on the screen as it enters the Linux boot step. You may have to move the physical mouse to get the mouse pointer to appear. The system can come up in the suspend mode with the HDMI port in a sleep mode.
- b. After a minute or two a login screen will appear. You do not have to do anything at this point.
- c. After a minute or two the desktop will appear. It should be similar to the one shown in figure-1. HOWEVER, it will change from one release to the next, so do not expect your system to look exactly like the one in the figure, but it will be very similar.
- d. And at this point you are ready to go! *figure-16* shows the desktop after booting.



Fig. 3.16: Desktop Screen

9. Powering Down

- A. Press the power button momentarily.
- B. The system will power down automatically.
- C. Remove the power jack.

Chapter 4

BeagleBone Black Overview

The BeagleBone Black is the latest addition to the BeagleBoard.org family and like its predecessors, is designed to address the Open Source Community, early adopters, and anyone interested in a low cost ARM Cortex-A8 based processor.

It has been equipped with a minimum set of features to allow the user to experience the power of the processor and is not intended as a full development platform as many of the features and interfaces supplied by the processor are not accessible from the BeagleBone Black via onboard support of some interfaces. It is not a complete product designed to do any particular function. It is a foundation for experimentation and learning how to program the processor and to access the peripherals by the creation of your own software and hardware.

It also offers access to many of the interfaces and allows for the use of add-on boards called capes, to add many different combinations of features. A user may also develop their own board or add their own circuitry.

BeagleBone Black is manufactured and warranted by partners listed at <https://beagleboard.org/logo> for the benefit of the community and its supporters.

Jason Kridner of Texas Instruments handles the community promotions and is the spokesman for BeagleBoard.org.

The board is designed by Gerald Coley of EmProDesign, a charter member of the BeagleBoard.org community.

The PCB layout up through PCB revision B was done by Circuitco and Circuitco is the sole funder of its development and transition to production. Later PCB revisions have been made by Embest, a subsidiary of Avent.

The Software is written and supported by the thousands of community members, including Jason Kridner, employee of Texas Instruments, and Robert Nelson, employee of DigiKey.

4.1 BeagleBone Compatibility

The board is intended to be compatible with the original BeagleBone as much as possible. There are several areas where there are differences between the two designs. These differences are listed below, along with the reasons for the differences.

- Sitara AM3358BZCZ100, 1GHZ, processor.
 - Sorry, we just had to make it faster.
- 512MB DDR3L
 - *Cost reduction*
 - Performance boost
 - Memory size increase
 - Lower power
- No Serial port by default

- *Cost reduction*
- Can be added by buying a TTL to USB Cable that is widely available
- Single largest cost reduction action taken
- No JTAG emulation over USB
 - *Cost reduction* JTAG header is not populated, but can easily be mounted.
 - EEPROM Reduced from 32KB to 4KB
 - *Cost Reduction*
- Onboard Managed NAND (eMMC)
 - 4GB
 - *Cost reduction*
 - Performance boost x8 vs. x4 bits
 - Performance boost due to deterministic properties vs. microSD card
- GPMC bus may not be accessible from the expansion headers in some cases
 - Result of eMMC on the main board
 - Signals are still routed to the expansion connector
 - If eMMC is not used, signals can be used via expansion if eMMC is held in reset
- There may be 10 less GPIO pins available
 - Result of eMMC
 - If eMMC is not used, could still be used
- The power expansion header, for battery and backlight, has been removed
 - **Cost reduction** , space reduction
 - Four pins were added to provide access to the battery charger function.
- HDMI interface onboard
 - Feature addition
 - Audio and video capable
 - Micro HDMI
- No three function USB cable
 - *Cost reduction*
- GPIO3_21 has a 24.576 MHZ clock on it.
 - This is required by the HDMI Framer for Audio purposes. We needed to run a clock into the processor to generate the correct clock frequency. The pin on the processor was already routed to the expansion header. In order not to remove this feature on the expansion header, it was left connected. In order to use the pin as a GPIO pin, you need to disable the clock. While this disables audio to the HDMI, the fact that you want to use this pin for something else, does the same thing.

4.2 BeagleBone Black Features and Specification

This section covers the specifications and features of the board and provides a high level description of the major components and interfaces that make up the board. table below provides a list of the features.

Table 4.1: BeagleBone Black Features

	Feature
Processor	Sitara AM3358BZCZ100 1GHz, 2000 MIPS
Graphics Engine	SGX530 3D, 20M Polygons/S
SDRAM Memory	512MB DDR3L 800MHZ
Onboard Flash	4GB, 8bit Embedded MMC
PMIC	TPS65217C PMIC regulator and one additional LDO.
Debug Support	Optional Onboard 20-pin CTI JTAG, Serial Header
Power Source	miniUSB USB or DC Jack
PCB	3.4" x 2.1"
Indicators	1-Power, 2-Ethernet, 4-User Controllable LEDs
HS USB 2.0 Client Port	Access to USB0, Client mode via miniUSB
HS USB 2.0 Host Port	Access to USB1, Type A Socket, 500mA LS/FS/HS
Serial Port	UART0 access via 6 pin 3.3V TTL Header. Header is populated
Ethernet	10/100, RJ45
SD/MMC Connector	microSD , 3.3V
User Input	<ol style="list-style-type: none"> 1. Reset Button 2. Boot Button 3. Power Button
Video Out	<ol style="list-style-type: none"> 1. 16b HDMI, 1280x1024 (MAX) 2. 1024x768,1280x720,1440x900 ,1920x1080@24Hz w/EDID Support
Audio	Via HDMI Interface, Stereo
Expansion Connectors	<ol style="list-style-type: none"> 1. Power 5V, 3.3V , VDD_ADC(1.8V) 2. 3.3V I/O on all signals 3. McASP0, SPI1, I2C, GPIO(69 max), LCD, GPMC, MMC1, MMC2, 7 4. AIN_(1.8V MAX)_, 4 Timers, 4 Serial Ports, CAN0, 5. EHRPWM(0,2),XDMA Interrupt, Power button, Expansion Board ID (Up to 4 can be stacked)
Weight	1.4 oz (39.68 grams)
Power	Refer to <i>section-6-1-7</i>

4.3 Board Component Locations

This section describes the key components on the board. It provides information on their location and function. Familiarize yourself with the various components on the board.

4.3.1 Connectors, LEDs, and Switches

figure below shows the locations of the connectors, LEDs, and switches on the PCB layout of the board.

- *DC Power* is the main DC input that accepts 5V power.
- *Power Button* alerts the processor to initiate the power down sequence and is used to power down the board.
- *10/100 Ethernet* is the connection to the LAN.

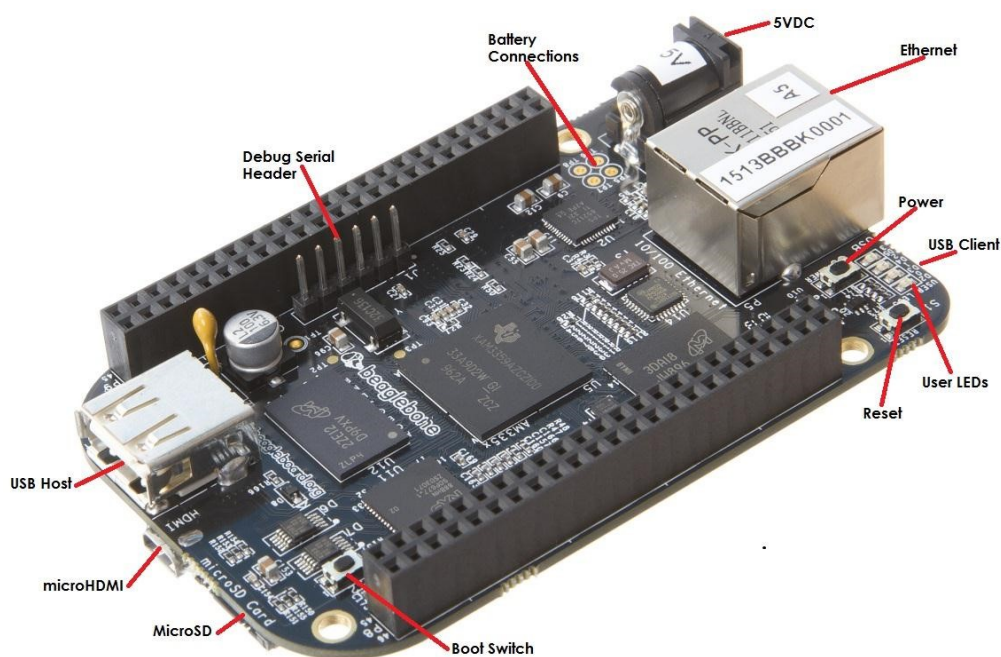

Fig. 4.1: Connectors, LEDs and Switches

- *Serial Debug* is the serial debug port.
- *USB Client* is a miniUSB connection to a PC that can also power the board.
- *BOOT switch* can be used to force a boot from the microSD card if the power is cycled on the board, removing power and reapplying the power to the board..
- There are four blue **LED**'s that can be used by the user.
- *Reset Button* allows the user to reset the processor.
- *microSD* slot is where a microSD card can be installed.
- *microHDMI* connector is where the display is connected to.
- *USB Host* can be connected different USB interfaces such as Wi-Fi, BT, Keyboard, etc.

4.3.2 Key Components

figure below shows the locations of the key components on the PCB layout of the board.

- *Sitara AM3358BZCZ100* is the processor for the board.
- *Micron 512MB DDR3L* or *Kingston 512mB DDR3* is the Dual Data Rate RAM memory.
- *TPS65217C PMIC* provides the power rails to the various components on the board.
- *SMSC Ethernet PHY* is the physical interface to the network.
- *Micron eMMC* is an onboard MMC chip that holds up to 4GB of data.
- *HDMI Framer* provides control for an HDMI or DVI-D display with an adapter.

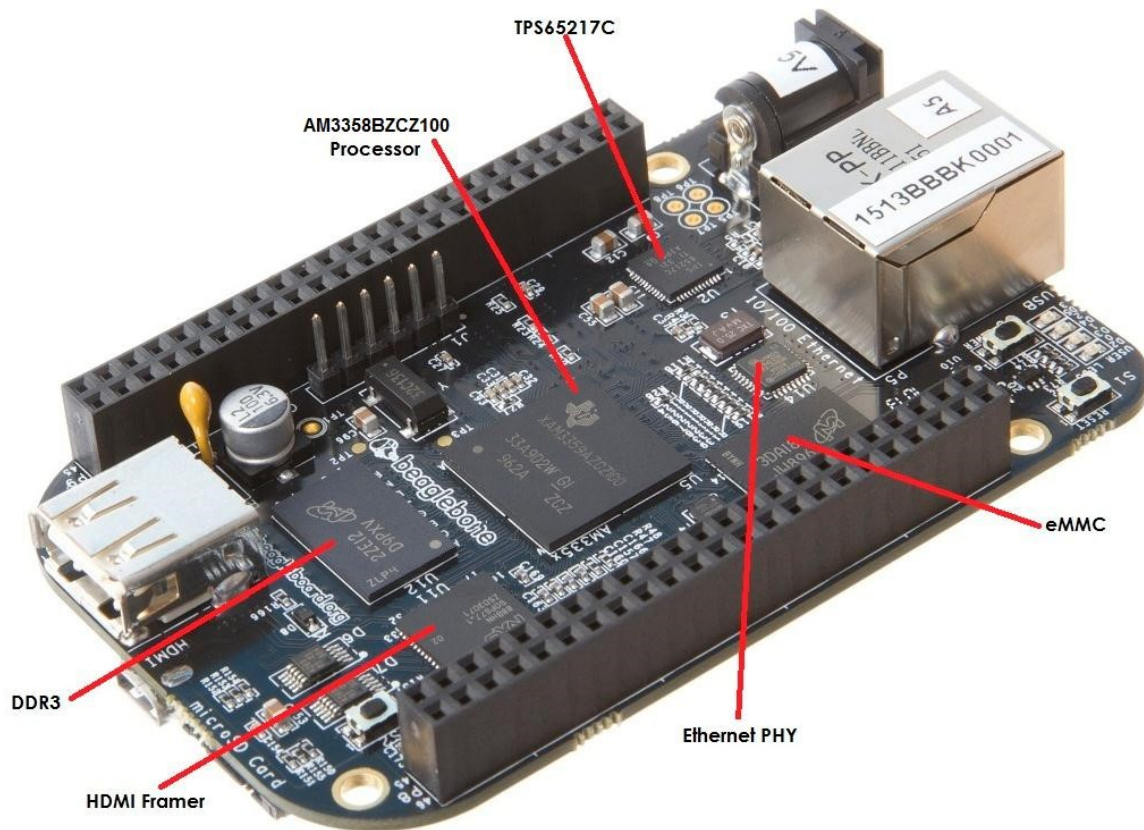

Fig. 4.2: Key Components

Chapter 5

BeagleBone Black High Level Specification

This section provides the high level specification of the BeagleBone Black.

5.1 Block Diagram

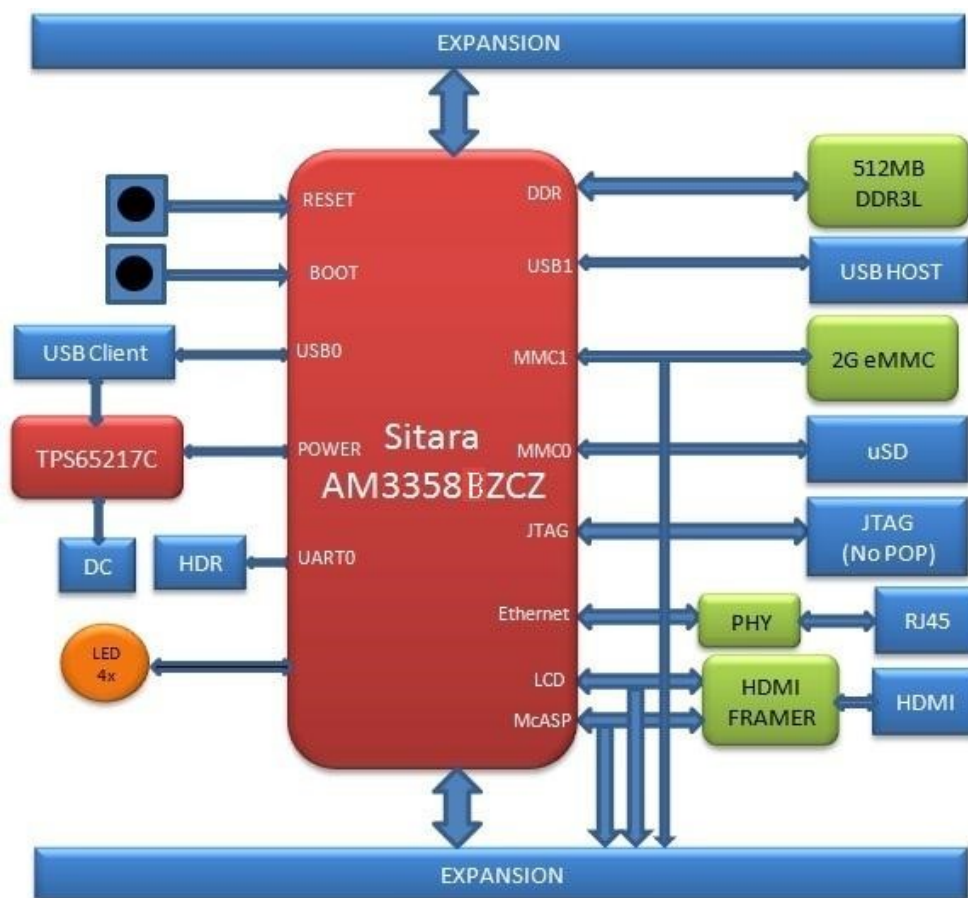

Fig. 5.1: BeagleBone Black Key Components

5.2 Processor

The revision B and later boards have moved to the Sitara AM3358BZCZ100 device.

5.3 Memory

Described in the following sections are the three memory devices found on the board.

5.3.1 512MB DDR3L

A single 256Mb x16 DDR3L 4Gb (512MB) memory device is used. The memory used is one of two devices:

- MT41K256M16HA-125 from Micron
- D2516EC4BXGGB from Kingston

It will operate at a clock frequency of 400MHz yielding an effective rate of 800MHZ on the DDR3L bus allowing for 1.6GB/S of DDR3L memory bandwidth.

5.3.2 4KB EEPROM

A single 4KB EEPROM is provided on I2C0 that holds the board information. This information includes board name, serial number, and revision information. This is not the same as the one used on the original BeagleBone. The device was changed for cost reduction reasons. It has a test point to allow the device to be programmed and otherwise to provide write protection when not grounded.

5.3.3 4GB Embedded MMC

A single 4GB embedded MMC (eMMC) device is on the board. The device connects to the MMC1 port of the processor, allowing for 8bit wide access. Default boot mode for the board will be MMC1 with an option to change it to MMC0, the SD card slot, for booting from the SD card as a result of removing and reapplying the power to the board. Simply pressing the reset button will not change the boot mode. MMC0 cannot be used in 8Bit mode because the lower data pins are located on the pins used by the Ethernet port. This does not interfere with SD card operation but it does make it unsuitable for use as an eMMC port if the 8 bit feature is needed.

5.3.4 microSD Connector

The board is equipped with a single microSD connector to act as the secondary boot source for the board and, if selected as such, can be the primary boot source. The connector will support larger capacity microSD cards. The microSD card is not provided with the board. Booting from MMC0 will be used to flash the eMMC in the production environment or can be used by the user to update the SW as needed.

5.3.5 Boot Modes

As mentioned earlier, there are four boot modes:

- **eMMC Boot:** This is the default boot mode and will allow for the fastest boot time and will enable the board to boot out of the box using the pre-flashed OS image without having to purchase a microSD card or a microSD card writer.
- **SD Boot:** This mode will boot from the microSD slot. This mode can be used to override what is on the eMMC device and can be used to program the eMMC when used in the manufacturing process or for field updates.

- **Serial Boot:** This mode will use the serial port to allow downloading of the software direct. A separate USB to serial cable is required to use this port.
- **USB Boot:** This mode supports booting over the USB port.

Software to support USB and serial boot modes is not provided by beagleboard.org. Please contact TI for support of this feature.

A switch is provided to allow switching between the modes.

- Holding the boot switch down during a removal and reapplication of power without a microSD card inserted will force the boot source to be the USB port and if nothing is detected on the USB client port, it will go to the serial port for download.
- Without holding the switch, the board will boot try to boot from the eMMC. If it is empty, then it will try booting from the microSD slot, followed by the serial port, and then the USB port.
- If you hold the boot switch down during the removal and reapplication of power to the board, and you have a microSD card inserted with a bootable image, the board will boot from the microSD card.

NOTE: Pressing the RESET button on the board will NOT result in a change of the `_boot` mode. You MUST remove power and reapply power to change the boot mode. The boot pins are sampled during power on reset from the PMIC to the processor. The reset button on the board is a warm reset only and will not force a boot mode change.

5.4 Power Management

The *TPS65217C* power management device is used along with a separate LDO to provide power to the system. The *TPS65217C* version provides for the proper voltages required for the DDR3L. This is the same device as used on the original BeagleBone with the exception of the power rail configuration settings which will be changed in the internal EEPROM to the *TPS65217C* to support the new voltages.

DDR3L requires 1.5V instead of 1.8V on the DDR2 as is the case on the original BeagleBone. The 1.8V regulator setting has been changed to 1.5V for the DDR3L. The LDO3 3.3V rail has been changed to 1.8V to support those rails on the processor. LDO4 is still 3.3V for the 3.3V rails on the processor. An external *LDOTLV70233* provides the 3.3V rail for the rest of the board.

5.4.1 PC USB Interface

The board has a miniUSB connector that connects the USB0 port to the processor. This is the same connector as used on the original BeagleBone.

5.4.2 Serial Debug Port

Serial debug is provided via UART0 on the processor via a single 1x6 pin header. In order to use the interface a USB to TTL adapter will be required. The header is compatible with the one provided by FTDI and can be purchased for about \$12 to \$20 from various sources. Signals supported are TX and RX. None of the handshake signals are supported.

5.4.3 USB1 Host Port

On the board is a single USB Type A female connector with full LS/FS/HS Host support that connects to USB1 on the processor. The port can provide power on/off control and up to 500mA of current at 5V. Under USB power, the board will not be able to supply the full 500mA, but should be sufficient to supply enough current for a lower power USB device supplying power between 50 to 100mA.

You can use a wireless keyboard/mouse configuration or you can add a HUB for standard keyboard and mouse interfacing.

5.4.4 Power Sources

The board can be powered from four different sources:

- A USB port on a PC
- A 5VDC 1A power supply plugged into the DC connector.
- A power supply with a USB connector.
- Expansion connectors

The USB cable is shipped with each board. This port is limited to 500mA by the Power Management IC. It is possible to change the settings in the *TPS65217C* to increase this current, but only after the initial boot. And, at that point the PC most likely will complain, but you can also use a dual connector USB cable to the PC to get to 1A.

The power supply is not provided with the board but can be easily obtained from numerous sources. A 1A supply is sufficient to power the board, but if there is a cape plugged into the board or you have a power hungry device or hub plugged into the host port, then more current may be needed from the DC supply.

Power routed to the board via the expansion header could be provided from power derived on a cape. The DC supply should be well regulated and 5V +/-0.25V.

5.4.5 Reset Button

When pressed and released, causes a reset of the board. The reset button used on the BeagleBone Black is a little larger than the one used on the original BeagleBone. It has also been moved out to the edge of the board so that it is more accessible.

5.4.6 Power Button

A power button is provided near the reset button close to the Ethernet connector. This button takes advantage of the input to the PMIC for power down features. While a lot of capes have a button, it was decided to add this feature to the board to ensure everyone had access to some new features. These features include:

- Interrupt is sent to the processor to facilitate an orderly shutdown to save files and to un-mount drives.
- Provides ability to let processor put board into a sleep mode to save power.
- Can alert processor to wake up from sleep mode and restore state before sleep was entered.

If you hold the button down longer than 8 seconds, the board will power off if you release the button when the power LED turns off. If you continue to hold it, the board will power back up completing a power cycle.

We recommend that you use this method to power down the board. It will also help prevent contamination of the SD card or the eMMC.

If you do not remove the power jack, you can press the button again and the board will power up.

5.4.7 Indicators

There are a total of five blue LEDs on the board.

- One blue power LED indicates that power is applied and the power management IC is up. If this LED flashes when applying power, it means that an excess current flow was detected and the PMIC has shut down.
- Four blue LEDs that can be controlled via the SW by setting GPIO pins.

In addition, there are two LEDs on the RJ45 to provide Ethernet status indication. One is yellow (100M Link up if on) and the other is green (Indicating traffic when flashing).

5.4.8 CTI JTAG Header

A place for an optional 20 pin CTI JTAG header is provided on the board to facilitate the SW development and debugging of the board by using various JTAG emulators. This header is not supplied standard on the board. To use this, a connector will need to be soldered onto the board.

If you need the JTAG connector you can solder it on yourself. No other components are needed. The connector is made by Samtec and the part number is FTR-110-03-G-D-06. You can purchase it from <http://www.digikey.com/>

5.4.9 HDMI Interface

A single HDMI interface is connected to the 16 bit LCD interface on the processor. The 16b interface was used to preserve as many expansion pins as possible to allow for use by the user. The NXP TDA19988BHN is used to convert the LCD interface to HDMI and convert the audio as well. The signals are still connected to the expansion headers to enable the use of LCD expansion boards or access to other functions on the board as needed.

The HDMI device does not support HDCP copy protection. Support is provided via EDID to allow the SW to identify the compatible resolutions. Currently the following resolutions are supported via the software:

- 1280 x 1024
- 1440 x 900
- 1024 x 768
- 1280 x 720

5.4.10 Cape Board Support

The BeagleBone Black has the ability to accept up to four expansion boards or capes that can be stacked onto the expansion headers. The word cape comes from the shape of the board as it is fitted around the Ethernet connector on the main board. This notch acts as a key to ensure proper orientation of the cape.

The majority of capes designed for the original BeagleBone will work on the BeagleBone Black. The two main expansion headers will be populated on the board. There are a few exceptions where certain capabilities may not be present or are limited to the BeagleBone Black. These include:

- GPMC bus may NOT be available due to the use of those signals by the eMMC. If the eMMC is used for booting only and the file system is on the microSD card, then these signals could be used.
- Another option is to use the microSD or serial boot modes and not use the eMMC.
- The power expansion header is not on the BeagleBone Black so those functions are not supported.

For more information on cape support refer to [BeagleBone Black Mechanical](#) section.

Chapter 6

Detailed Hardware Design

This section provides a detailed description of the Hardware design. This can be useful for interfacing, writing drivers, or using it to help modify specifics of your own design.

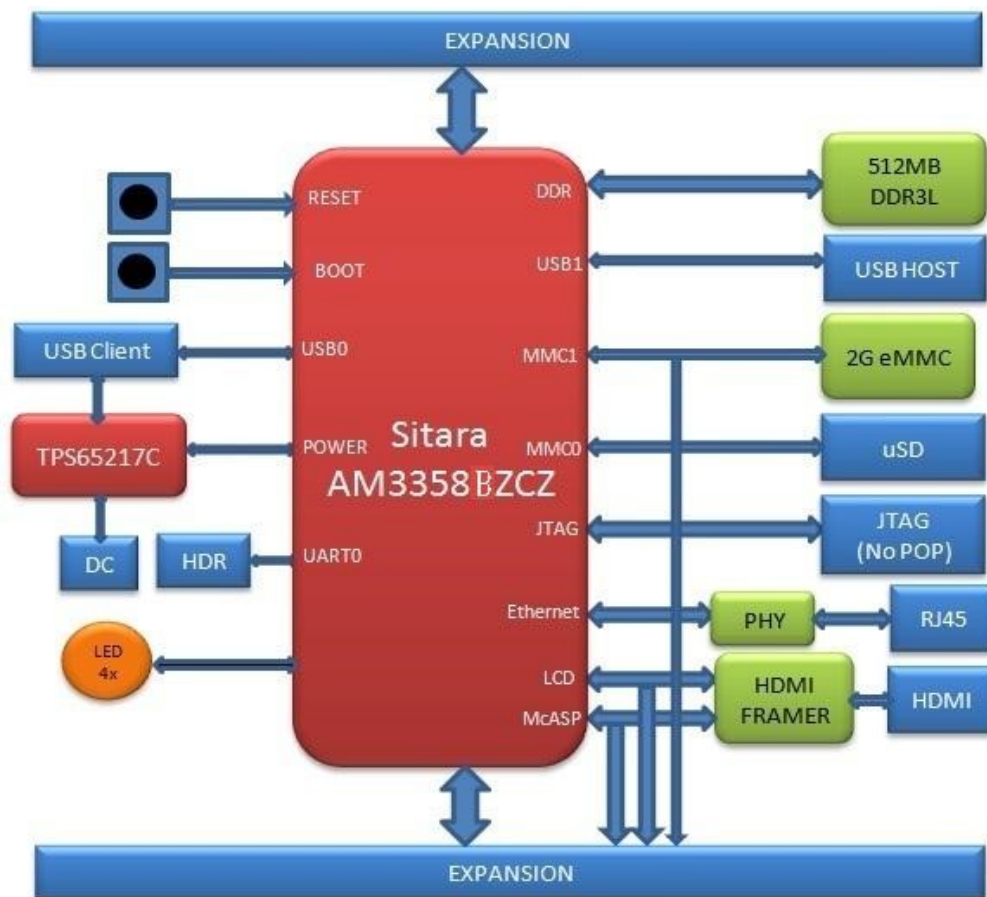

Fig. 6.1: BeagleBone Black Block Diagram

6.1 Power Section

This section describes the power section of the design and all the functions performed by the *TPS65217C*.

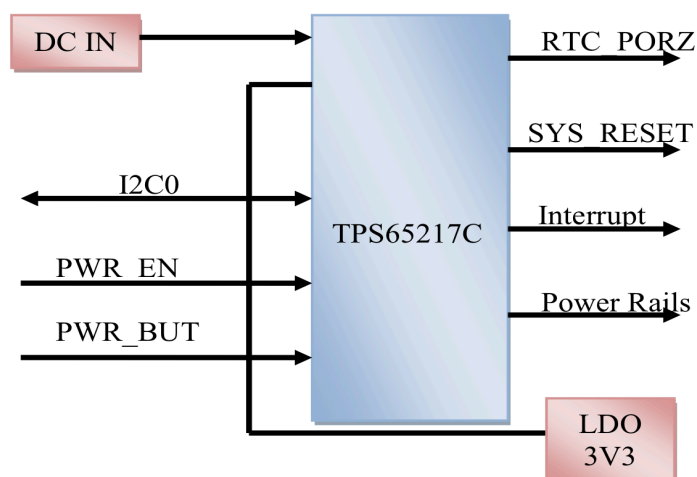

Fig. 6.2: High Level Power Block Diagram

6.1.1 TPS65217C PMIC

The main Power Management IC (PMIC) in the system is the *TPS65217C* which is a single chip power management IC consisting of a linear dual-input power path, three step-down converters, and four LDOs. LDO stands for Low Drop Out. If you want to know more about an LDO, you can go to http://en.wikipedia.org/wiki/Low-dropout_regulator. If you want to learn more about step-down converters, you can go to http://en.wikipedia.org/wiki/DC-to-DC_converter

The system is supplied by a USB port or DC adapter. Three high-efficiency 2.25MHz step-down converters are targeted at providing the core voltage, MPU, and memory voltage for the board.

The step-down converters enter a low power mode at light load for maximum efficiency across the widest possible range of load currents. For low-noise applications the devices can be forced into fixed frequency PWM using the I2C interface. The step-down converters allow the use of small inductors and capacitors to achieve a small footprint solution size.

LDO1 and LDO2 are intended to support system standby mode. In normal operation, they can support up to 100mA each. LDO3 and LDO4 can support up to 285mA each.

By default only LDO1 is always ON but any rail can be configured to remain up in SLEEP state. In particular the DCDC converters can remain up in a low-power PFM mode to support processor suspend mode. The *TPS65217C* offers flexible power-up and power-down sequencing and several house-keeping functions such as power-good output, pushbutton monitor, hardware reset function and temperature sensor to protect the battery.

For more information on the *TPS65217C*, refer to <http://www.ti.com/product/tps65217c>

6.1.2 DC Input

A 5VDC supply can be used to provide power to the board. The power supply current depends on how many and what type of add-on boards are connected to the board. For typical use, a 5VDC supply rated at 1A should be sufficient. If heavier use of the expansion headers or USB host port is expected, then a higher current supply will be required.

The connector used is a 2.1MM center positive x 5.5mm outer barrel. The 5VDC rail is connected to the expansion header. It is possible to power the board via the expansion headers from an add-on card. The 5VDC is also available for use by the add-on cards when the power is supplied by the 5VDC jack on the board.

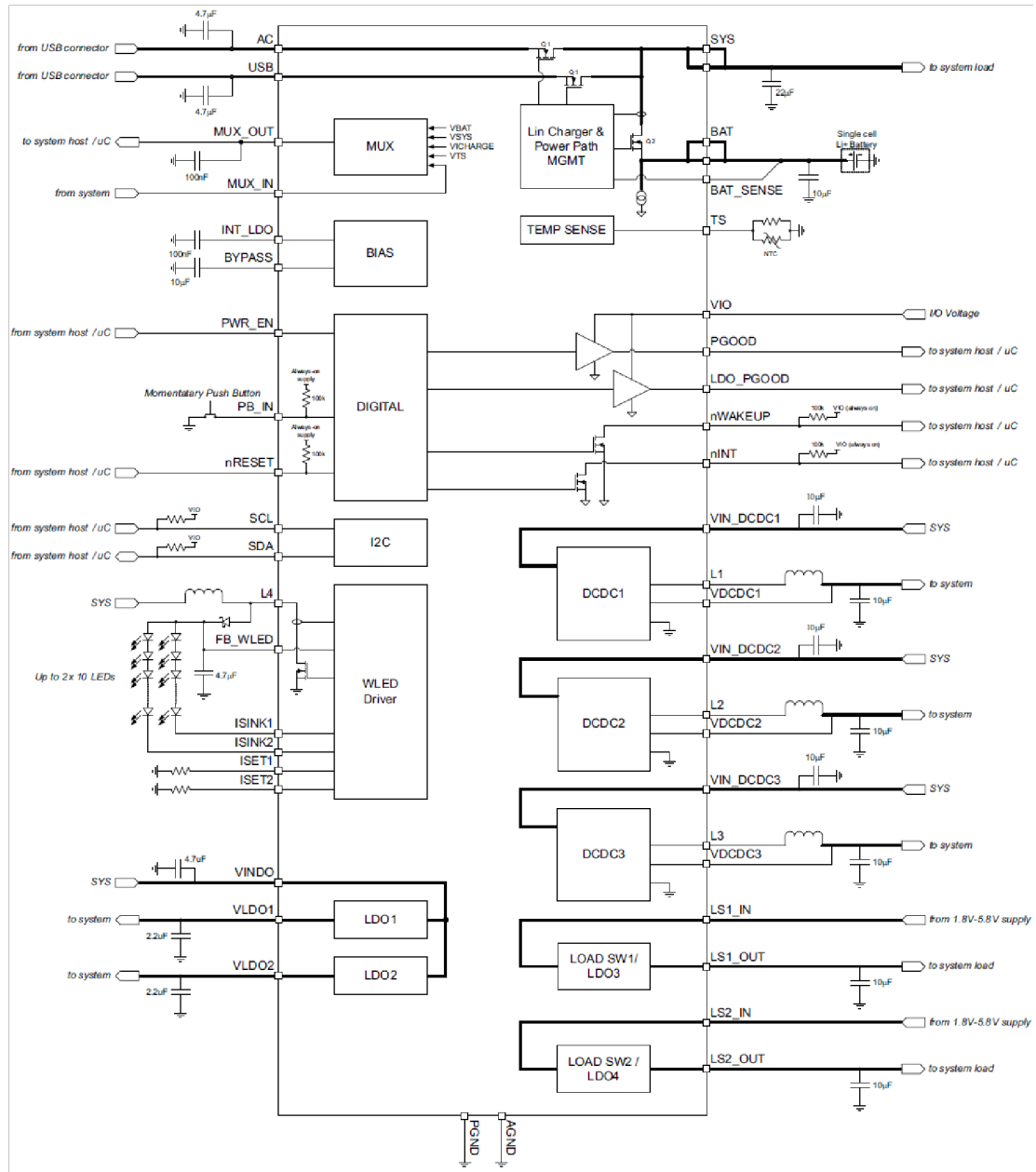

Fig. 6.3: TPS65217C Block Diagram

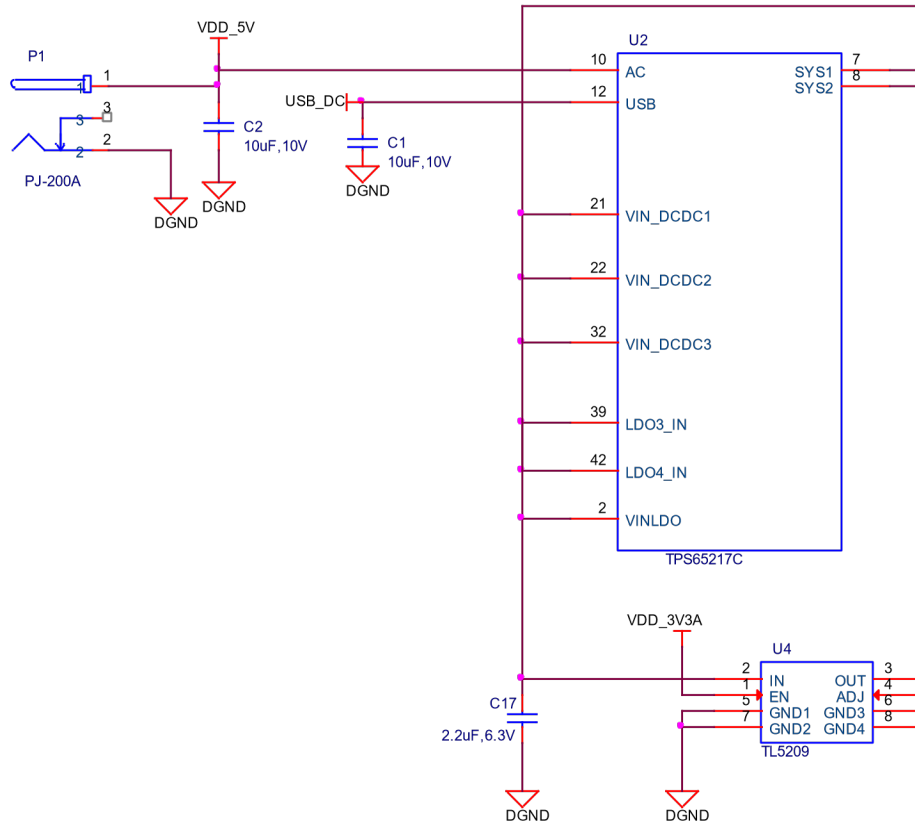

Fig. 6.4: TPS65217 DC Connection

6.1.3 USB Power

The board can also be powered from the USB port. A typical USB port is limited to 500mA max. When powering from the USB port, the VDD_5V rail is not provided to the expansion headers, so capes that require the 5V rail to supply the cape direct, bypassing the *TPS65217C*, will not have that rail available for use. The 5VDC supply from the USB port is provided on the SYS_5V, the one that comes from the *TPS65217C*, rail of the expansion header for use by a cape. *Figure 24* is the connection of the USB power input on the PMIC.

6.1.4 Power Selection

The selection of either the 5VDC or the USB as the power source is handled internally to the *TPS65217C* and automatically switches to 5VDC power if both are connected. SW can change the power configuration via the I2C interface from the processor. In addition, the SW can read the *TPS65217C* and determine if the board is running on the 5VDC input or the USB input. This can be beneficial to know the capability of the board to supply current for things like operating frequency and expansion cards.

It is possible to power the board from the USB input and then connect the DC power supply. The board will switch over automatically to the DC input.

6.1.5 Power Button

A power button is connected to the input of the *TPS65217C*. This is a momentary switch, the same type of switch used for reset and boot selection on the board.

If you push the button the *TPS65217C* will send an interrupt to the processor. It is up to the processor to then pull the *PMIC_POWER_EN* pin low at the correct time to power down the board. At this point, the PMIC is still active, assuming that the power input was not removed. Pressing the power button will cause the board to power up again if the processor puts the board in the power off mode.

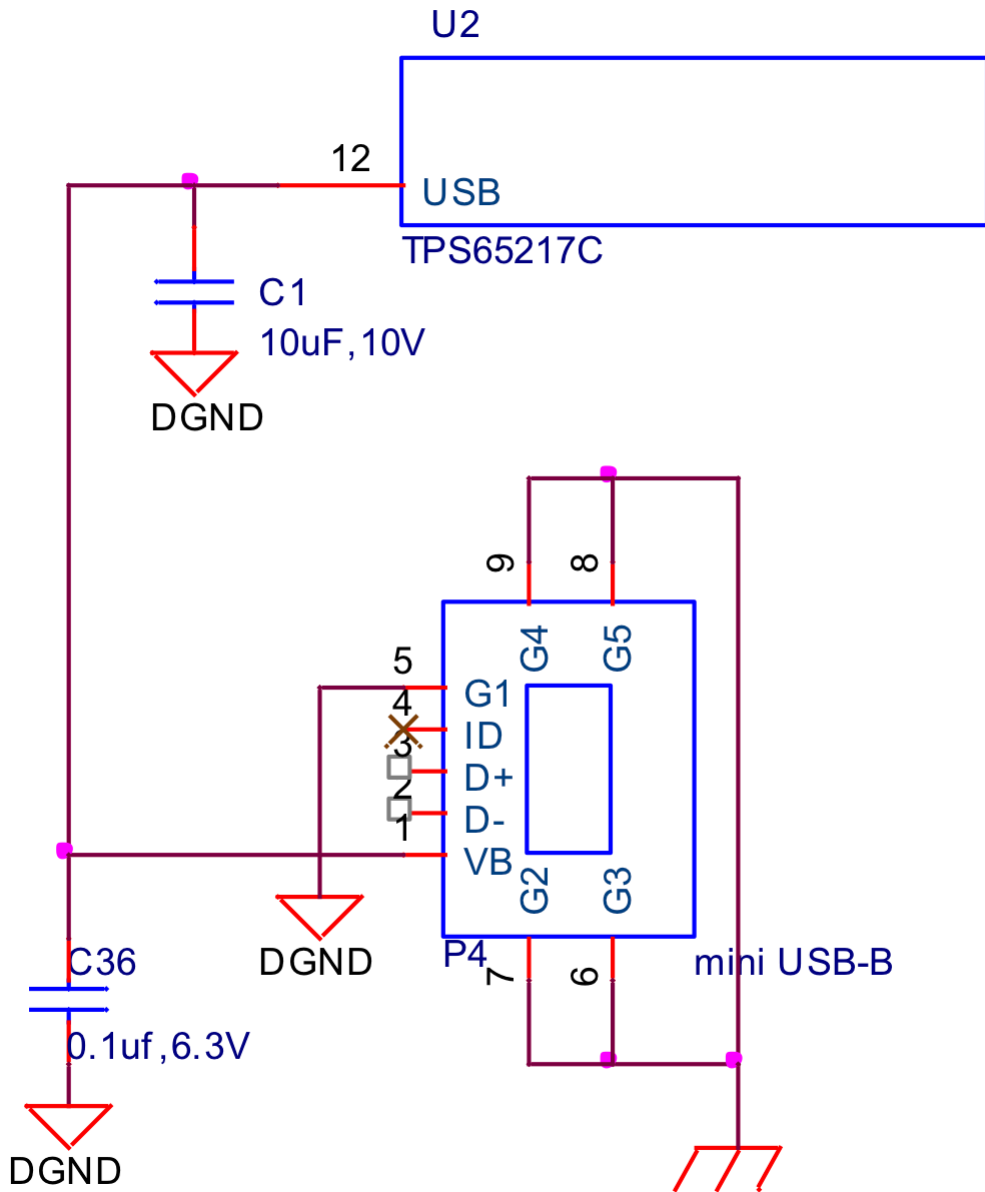

Fig. 6.5: USB Power Connections

In power off mode, the RTC rail is still active, keeping the RTC powered and running off the main power input. If you remove that power, then the RTC will not be powered. You also have the option of using the battery holes on the board to connect a battery if desired as discussed in the next section.

If you push and hold the button for greater than 8 seconds, the PMIC will power down. But you must release the button when the power LED turns off. Holding the button past that point will cause the board to power cycle.

6.1.6 Battery Access Pads

Four pads are provided on the board to allow access to the battery pins on the *TPS65217C*. The pads can be loaded with a 4x4 header or you may just wire a battery into the pads. In addition they could provide access via a cape if desired. The four signals are listed below in *table-3*.

Table 6.1: BeagleBone Black Battery Pins

PIN	DESIGNATION	FUNCTION
BAT	TP5	Battery connection point
SENSE	TP6	Battery voltage sense input, connect to BAT directly at the battery terminal.
TS	TP7	Temperature sense input. Connect to NTC thermistor to sense battery temperature.
GND	TP8	System ground.

There is no fuel gauge function provided by the *TPS65217C*. That would need to be added if that function was required. If you want to add a fuel gauge, an option is to use 1-wire SPI or I2C device. You will need to add this using the expansion headers and place it on an expansion board.

NOTE: Refer to the TPS65217C documentation + before connecting anything to these pins.

6.1.7 Power Consumption

The power consumption of the board varies based on power scenarios and the board boot processes. Measurements were taken with the board in the following configuration:

- DC powered and USB powered
- HDMI monitor connected
- USB HUB
- 4GB USB flash drive
- Ethernet connected @ 100M
- Serial debug cable connected

Table 6.2: BeagleBone Black Power Consumption(mA@5V)

MODE	USB	DC	DC+USB
Reset	TBD	TBD	TBD
Idling @ UBoot	210	210	210
Kernel Booting (Peak)	460	460	460
Kernel Idling	350	350	350
Kernel Idling Display Blank	280	280	280
Loading a Webpage	430	430	430

The current will fluctuate as various activates occur, such as the LEDs on and microSD/eMMC accesses.

6.1.8 Processor Interfaces

The processor interacts with the *TPS65217C* via several different signals. Each of these signals is described below.

I2C0

I2C0 is the control interface between the processor and the *TPS65217C*. It allows the processor to control the registers inside the **TPS65217C** for such things as voltage scaling and switching of the input rails.

PMIC_POWER_EN

On power up the *VDD_RTC* rail activates first. After the RTC circuitry in the processor has activated it instructs the *TPS65217C* to initiate a full power up cycle by activating the *PMIC_POWER_EN* signal by taking it HI. When powering down, the processor can take this pin low to start the power down process.

LDO_GOOD

This signal connects to the *RTC_PORZn* signal, RTC power on reset. The small *n* indicates that the signal is an active low signal. Word processors seem to be unable to put a bar over a word so the ***n** is commonly used in electronics. As the RTC circuitry comes up first, this signal indicates that the LDOs, the 1.8V VRTC rail, is up and stable. This starts the power up process.

PMIC_PGOOD

Once all the rails are up, the *PMIC_PGOOD* signal goes high. This releases the **PORZn** signal on the processor which was holding the processor reset.

WAKEUP

The WAKEUP signal from the *TPS65217C* is connected to the **EXT_WAKEUP** signal on the processor. This is used to wake up the processor when it is in a sleep mode. When an event is detected by the *TPS65217C*, such as the power button being pressed, it generates this signal.

PMIC_INT

The *PMIC_INT* signal is an interrupt signal to the processor. Pressing the power button will send an interrupt to the processor allowing it to implement a power down mode in an orderly fashion, go into sleep mode, or cause it to wake up from a sleep mode. All of these require SW support.

6.1.9 Power Rails

VRTC Rail

The VRTC rail is a 1.8V rail that is the first rail to come up in the power sequencing. It provides power to the RTC domain on the processor and the I/O rail of the **TPS65217C**. It can deliver up to 250mA maximum.

VDD_3V3A Rail

The *VDD_3V3A* rail is supplied by the **TPS65217C** and provides the 3.3V for the processor rails and can provide up to 400mA.

VDD_3V3B Rail

The current supplied by the *VDD_3V3A* rail is not sufficient to power all of the 3.3V rails on the board. So a second LDO is supplied, U4, a **TL5209A**, which sources the *VDD_3V3B* rail. It is powered up just after the *VDD_3V3A* rail.

VDD_1V8 Rail

The *VDD_1V8* rail can deliver up to 400mA and provides the power required for the 1.8V rails on the processor and the HDMI framer. This rail is not accessible for use anywhere else on the board.

VDD_CORE Rail

The *VDD_CORE* rail can deliver up to 1.2A at 1.1V. This rail is not accessible for use anywhere else on the board and connects only to the processor. This rail is fixed at 1.1V and should not be adjusted by SW using the PMIC. If you do, then the processor will no longer work.

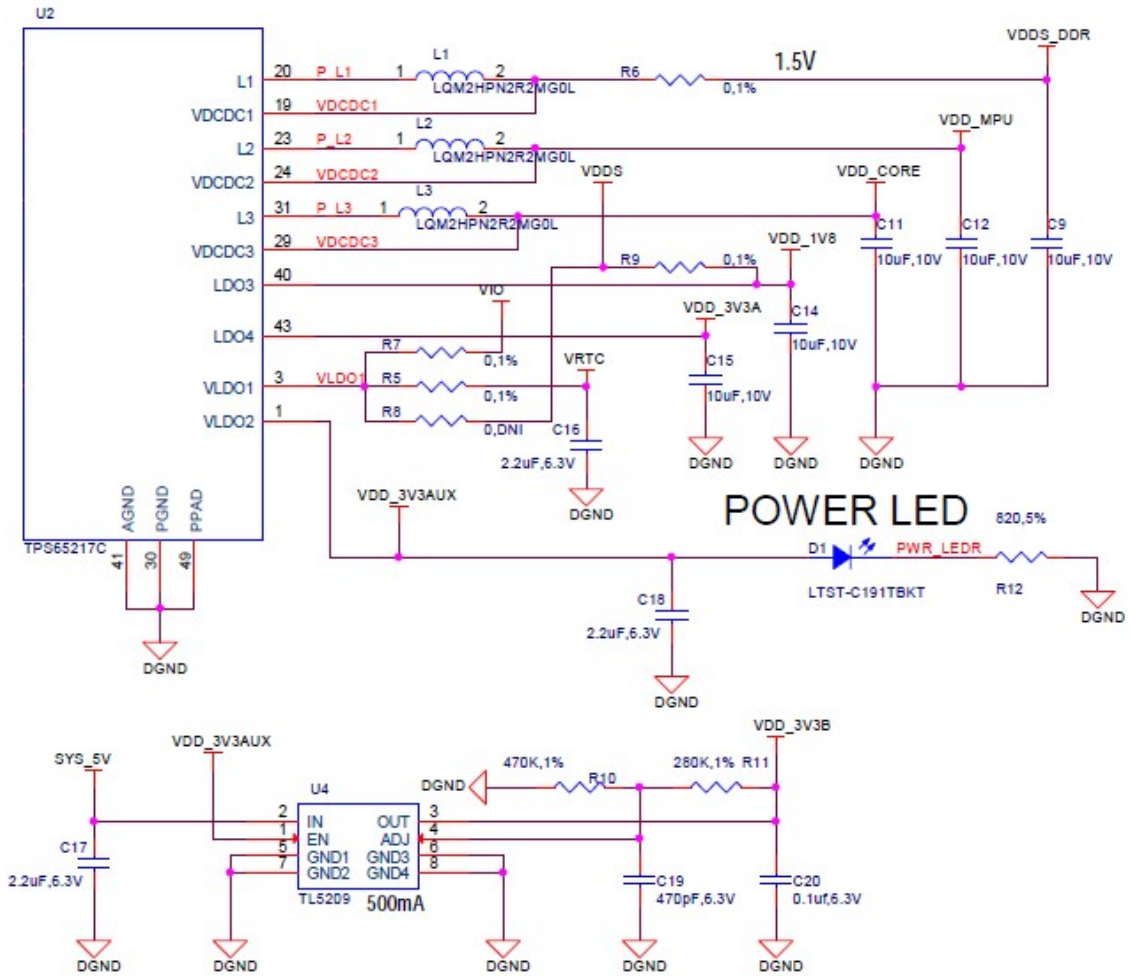

Fig. 6.6: Power Rails

VDD_MPU Rail

The *VDD_MPU* rail can deliver up to 1.2A. This rail is not accessible for use anywhere else on the board and connects only to the processor. This rail defaults to 1.1V and can be scaled up to allow for higher frequency operation. Changing of the voltage is set via the I2C interface from the processor.

VDDS_DDR Rail

The *VDDS_DDR* rail defaults to **1.5V** to support the DDR3L rails and can deliver up to 1.2A. It is possible to adjust this voltage rail down to 1.35V for lower power operation of the DDR3L device. Only DDR3L devices can support this voltage setting of 1.35V.

Power Sequencing

The power up process consists of several stages and events. *figure-26* describes the events that make up the power up process for the processor from the PMIC. This diagram is used elsewhere to convey additional information. I saw no need to bust it up into smaller diagrams. It is from the processor datasheet supplied by Texas Instruments.

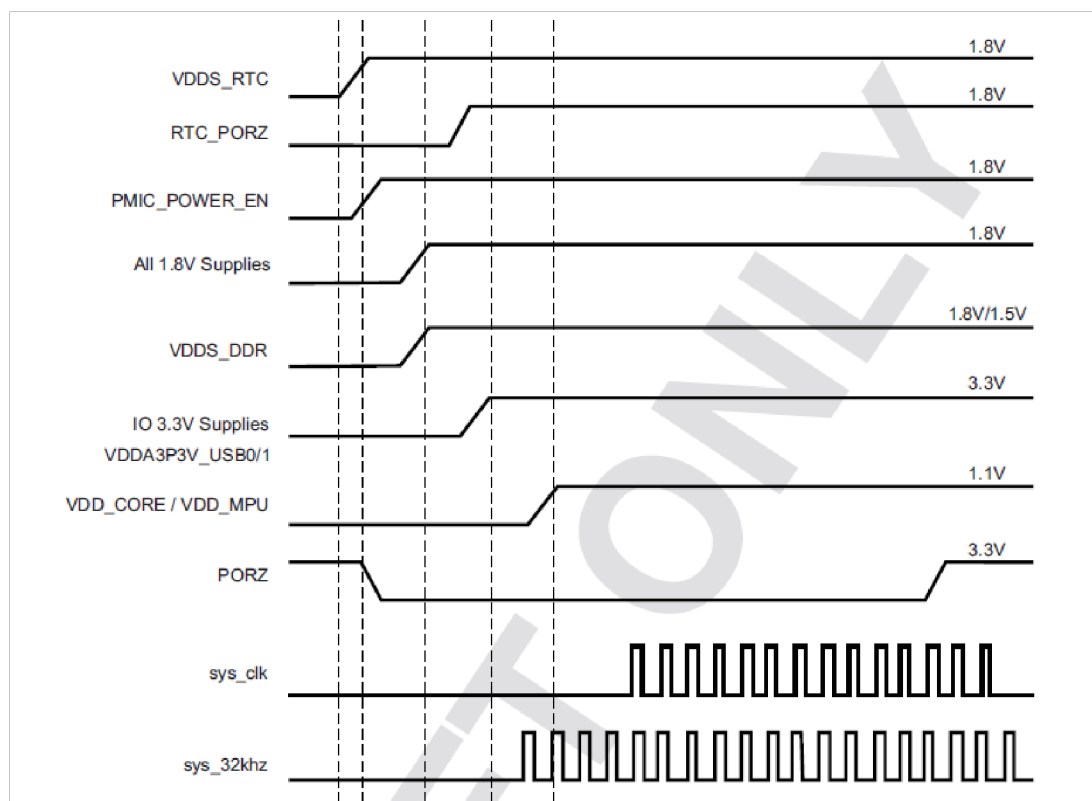

Fig. 6.7: Power Rail Power Up Sequencing

figure-27 the voltage rail sequencing for the **TPS65217C** as it powers up and the voltages on each rail. The power sequencing starts at 15 and then goes to one. That is the way the *TPS65217C* is configured. You can refer to the *TPS65217C* datasheet for more information.

6.1.10 Power LED

The power LED is a blue LED that will turn on once the *TPS65217C* has finished the power up procedure. If you ever see the LED flash once, that means that the **TPS65217C** started the process and encountered an issue that caused it to shut down. The connection of the LED is shown in *figure-25*.

TPS65217C (Targeted at AM335x - ZCZ)	
VOLTAGE (V)	SEQUENCE (STROBE)
1.5	1
1.1	5
1.1	5
1.8	15
3.3	3
1.8 (LDO, 400 mA)	2
3.3 (LDO, 400 mA)	4

Fig. 6.8: TPS65217C Power Sequencing Timing

6.1.11 TPS65217C Power Up Process

Figure below shows the interface between the **TPS65217C** and the processor. It is a cut from the PDF form of the schematic and reflects what is on the schematic.

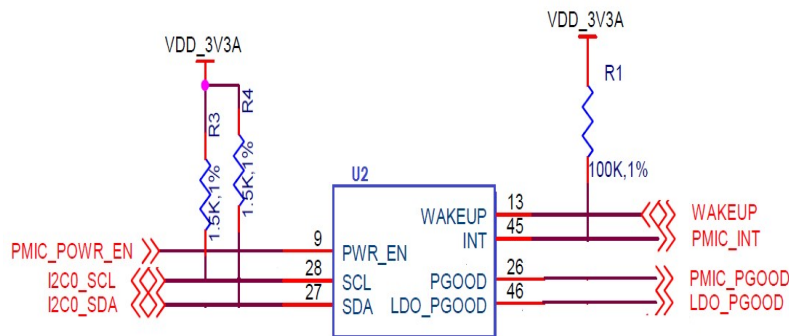

Fig. 6.9: Power Processor Interfaces

When voltage is applied, DC or USB, the *TPS65217C* connects the power to the SYS output pin which drives the switchers and LDOs in the **TPS65217C**.

At power up all switchers and LDOs are off except for the *VRTC LDO* (1.8V), which provides power to the *VRTC* rail and controls the **RTC_PORZn** input pin to the processor, which starts the power up process of the processor. Once the *RTC* rail powers up, the *RTC_PORZn* pin, driven by the *LDO_PGOOD* signal from the *TPS65217C*, of the processor is released.

Once the *RTC_PORZn* reset is released, the processor starts the initialization process. After the *RTC* stabilizes, the processor launches the rest of the power up process by activating the **PMIC_POWER_EN** signal that is connected to the *TPS65217C* which starts the *TPS65217C* power up process.

The *LDO_PGOOD* signal is provided by the *TPS65217C* to the processor. As this signal is 1.8V from the *TPS65217C* by virtue of the *TPS65217C* *VIO* rail being set to 1.8V, and the *RTC_PORZ* signal on the processor is 3.3V, a voltage level shifter, *U4*, is used. Once the LDOs and switchers are up on the *TPS65217C*, this signal goes active releasing the processor. The LDOs on the *TPS65217C* are used to power the *VRTC* rail on the processor.

6.1.12 Processor Control Interface

figure-28 above shows two interfaces between the processor and the **TPS65217C** used for control after the power up sequence has completed.

The first is the *I2C0* bus. This allows the processor to turn on and off rails and to set the voltage levels of each regulator to supports such things as voltage scaling.

The second is the interrupt signal. This allows the *TPS65217C* to alert the processor when there is an event, such as when the power button is pressed. The interrupt is an open drain output which makes it easy to interface to 3.3V of the processor.

6.1.13 Low Power Mode Support

This section covers three general power down modes that are available. These modes are only described from a Hardware perspective as it relates to the HW design.

RTC Only

In this mode all rails are turned off except the *VDD_RTC*. The processor will need to turn off all the rails to enter this mode. The **VDD_RTC** staying on will keep the RTC active and provide for the wakeup interfaces to be active to respond to a wake up event.

RTC Plus DDR

In this mode all rails are turned off except the *VDD_RTC* and the **VDDS_DDR**, which powers the DDR3L memory. The processor will need to turn off all the rails to enter this mode. The *VDD_RTC* staying on will keep the RTC active and provide for the wakeup interfaces to be active to respond to a wake up event.

The *VDDS_DDR* rail to the DDR3L is provided by the 1.5V rail of the **TPS65217C** and with *VDDS_DDR* active, the DDR3L can be placed in a self refresh mode by the processor prior to power down which allows the memory data to be saved.

Currently, this feature is not included in the standard software release. The plan is to include it in future releases.

Voltage Scaling

For a mode where the lowest power is possible without going to sleep, this mode allows the voltage on the ARM processor to be lowered along with slowing the processor frequency down. The *I2C0* bus is used to control the voltage scaling function in the *TPS65217C*.

6.2 Sitara AM3358BZCZ100 Processor

The board is designed to use the Sitara AM3358BZCZ100 processor in the 15 x 15 package. Earlier revisions of the board used the XM3359AZCZ100 processor.

6.2.1 Description

Figure below shows is a high level block diagram of the processor. For more information on the processor, go to <http://www.ti.com/product/am3358>

6.2.2 High Level Features

Table 6.3: Processor Features

Operating Systems	Linux, Android, Win- dows Embedded CE, QNX, ThreadX	MMC/SD	3
Standby Power	7 mW	CAN	2
ARM CPU	1 ARM Cortex-A8	UART (SCI)	6

continues on next page

Table 6.3 – continued from previous page

Operating Systems	Linux, Android, Windows Embedded CE, QNX, ThreadX	MMC/SD	3
ARM MHz (Max.)	275,500,600,800,1000	ADC	8-ch 12-bit
ARM MIPS (Max.)	1000,1200,2000	PWM (Ch)	3
Graphics Acceleration	1 3D	eCAP	3
Other Hardware Acceleration	2 PRU-ICSS, Crypto Accelerator	eQEP	3
On-Chip L1 Cache	64 KB (ARM Cortex-A8)	RTC	1
On-Chip L2 Cache	256 KB (ARM Cortex-A8)	I2C	3
Other On-Chip Memory	128 KB	McASP	2
Display Options	LCD	SPI	2
General Purpose Memory	1 16-bit (GPMC, NAND flash, NOR Flash, SRAM)	DMA (Ch)	64-Ch EDMA
DRAM	1 16-bit (LPDDR-400, DDR2-532, DDR3-400)	IO Supply (V)	1.8V(ADC), 3.3V
USB Ports	2	Operating Temperature Range (C)	40 to 90

6.2.3 Documentation

Full documentation for the processor can be found on the TI website at <http://www.ti.com/product/am3358> for the current processor used on the board. Make sure that you always use the latest datasheets and Technical Reference Manuals (TRM).

6.2.4 Crystal Circuitry

6.2.5 Reset Circuitry

figure-31 is the board reset circuitry. The initial power on reset is generated by the **TPS65217C** power management IC. It also handles the reset for the Real Time Clock.

The board reset is the SYS_RESETh signal. This is connected to the NRESET_INOUT pin of the processor. This pin can act as an input or an output. When the reset button is pressed, it sends a warm reset to the processor and to the system.

On the revision A5D board, a change was made. On power up, the NRESET_INOUT signal can act as an output. In this instance it can cause the SYS_RESETh line to go high prematurely. In order to prevent this, the PORZn signal from the TPS65217C is connected to the SYS_RESETh line using an open drain buffer. These ensure that the line does not momentarily go high on power up.

This change is also in all revisions after A5D.

DDR3L Memory

The BeagleBone Black uses a single MT41K256M16HA-125 512MB DDR3L device from Micron that interfaces to the processor over 16 data lines, 16 address lines, and 14 control lines. On rev C we added the Kingston *KE4CN2H5A-A58* device as a source for the DDR3L device**.**

The following sections provide more details on the design.

6.2.6 Memory Device

The design supports the standard DDR3 and DDR3L x16 devices and is built using the DDR3L. A single x16 device is used on the board and there is no support for two x8 devices. The DDR3 devices work at 1.5V and

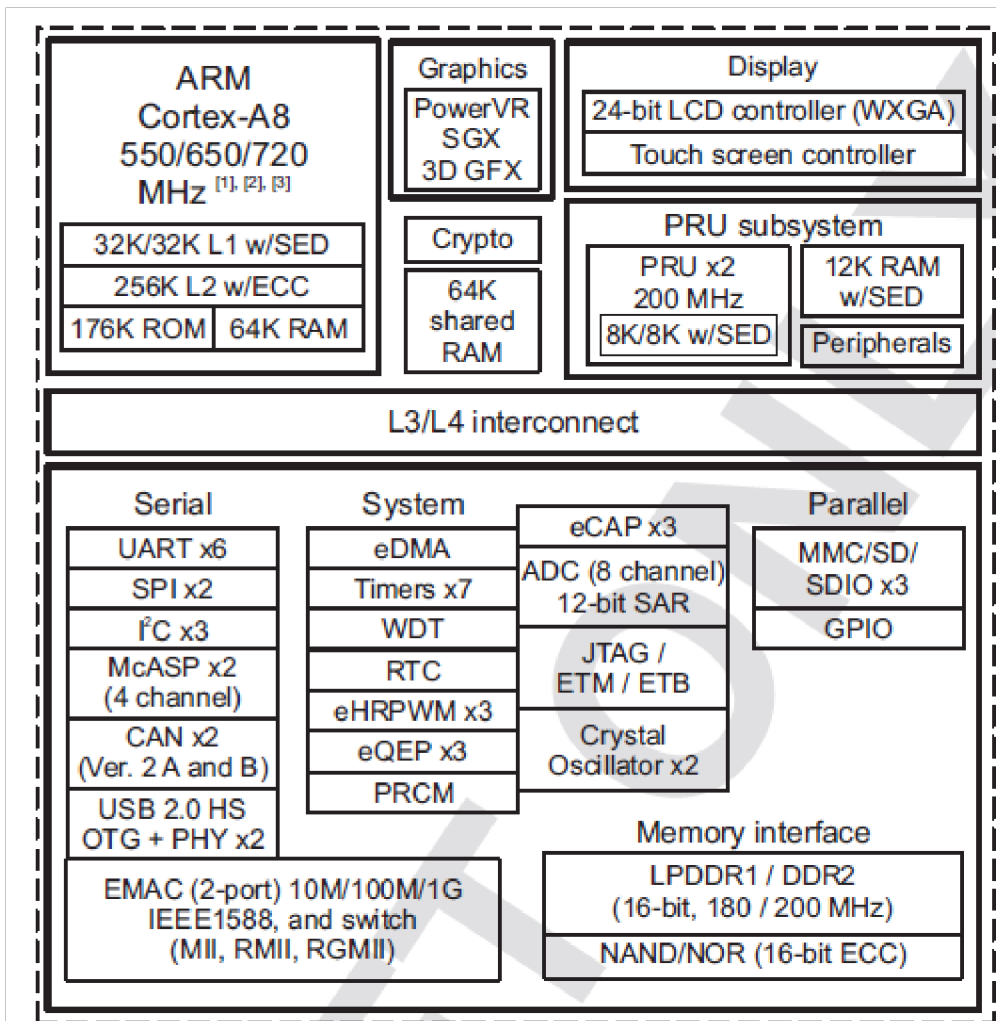

Fig. 6.10: Sitara AM3358BZCZ Block Diagram

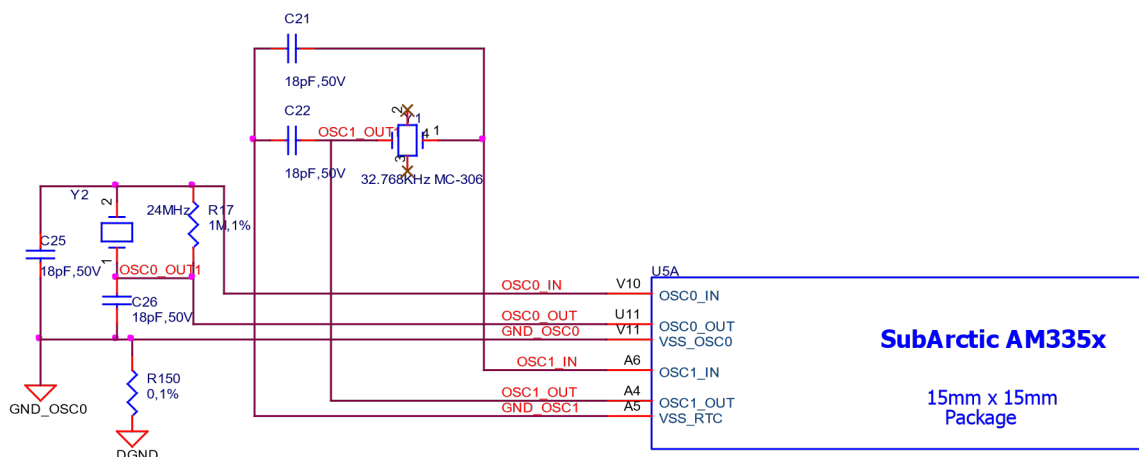

Fig. 6.11: Processor Crystals

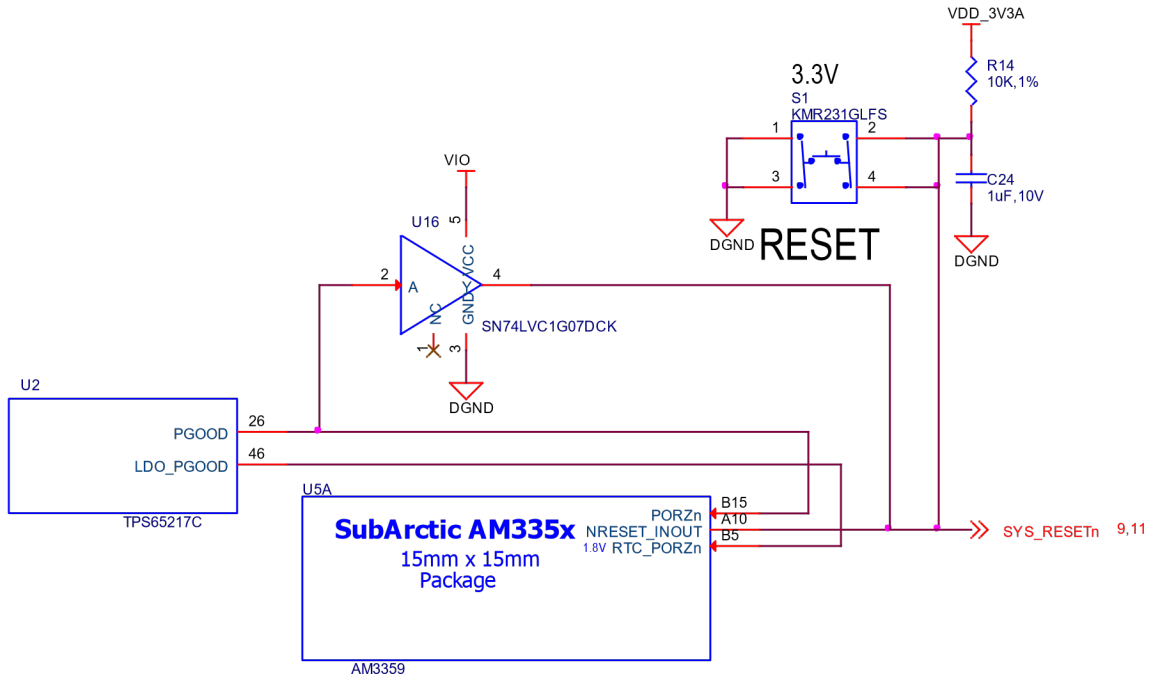

Fig. 6.12: Board Reset Circuitry

the DDR3L devices can work down to

1.35V to achieve lower power. The DDR3L comes in a 96-BALL FBGA package with 0.8 mil pitch. Other standard DDR3 devices can also be supported, but the DDR3L is the lower power device and was chosen for its ability to work at 1.5V or 1.35V. The standard frequency that the DDR3L is run at on the board is 400MHZ.

6.2.7 DDR3L Memory Design

figure-32 is the schematic for the DDR3L memory device. Each of the groups of signals is described in the following lines.

Address Lines: Provide the row address for ACTIVATE commands, and the column address and auto pre-charge bit (A10) for READ/WRITE commands, to select one location out of the memory array in the respective bank. A10 sampled during a PRECHARGE command determines whether the PRECHARGE applies to one bank (A10 LOW, bank selected by BA[2:0]) or all banks (A10 HIGH). The address inputs also provide the op-code during a LOAD MODE command. Address inputs are referenced to VREFCA. A12/BC#: When enabled in the mode register (MR), A12 is sampled during READ and WRITE commands to determine whether burst chop (on-the-fly) will be performed (HIGH = BL8 or no burst chop, LOW = BC4 burst chop).

Bank Address Lines: BA[2:0] define the bank to which an ACTIVATE, READ, WRITE, or PRECHARGE command is being applied. BA[2:0] define which mode register (MR0, MR1, MR2, or MR3) is loaded during the LOAD MODE command. BA[2:0] are referenced to VREFCA.

CK and CK# Lines: are differential clock inputs. All address and control input signals are sampled on the crossing of the positive edge of CK and the negative edge of CK#. Output data strobe (DQS, DQS#) is referenced to the crossings of CK and CK#.

Clock Enable Line: CKE enables (registered HIGH) and disables (registered LOW) internal circuitry and clocks on the DRAM. The specific circuitry that is enabled/disabled is dependent upon the DDR3 SDRAM configuration and operating mode. Taking CKE LOW provides PRECHARGE power-down and SELF REFRESH operations (all banks idle) or active power-down (row active in any bank). CKE is synchronous for powerdown entry and exit and for self refresh entry. CKE is asynchronous for self refresh exit. Input buffers (excluding CK, CK#, CKE, RESET#, and ODT) are disabled during powerdown. Input buffers (excluding CKE and RESET#) are disabled during SELF REFRESH. CKE is referenced to VREFCA.

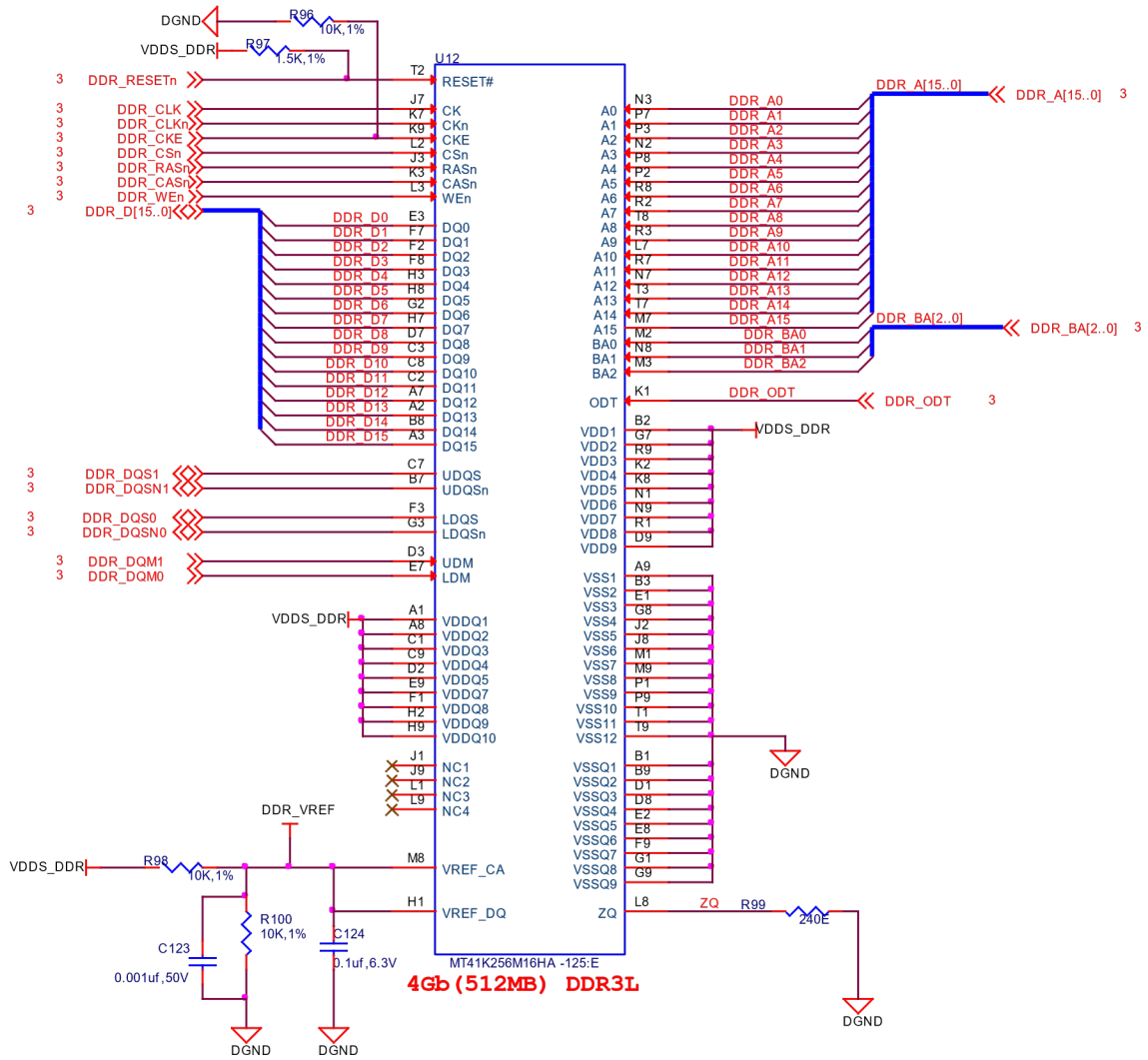

Fig. 6.13: DDR3L Memory Design

Chip Select Line: CS# enables (registered LOW) and disables (registered HIGH) the command decoder. All commands are masked when CS# is registered HIGH. CS# provides for external rank selection on systems with multiple ranks. CS# is considered part of the command code. CS# is referenced to VREFCA.

Input Data Mask Line: DM is an input mask signal for write data. Input data is masked when DM is sampled HIGH along with the input data during a write access. Although the DM ball is input-only, the DM loading is designed to match that of the DQ and DQS balls. DM is referenced to VREFDQ.

On-die Termination Line: ODT enables (registered HIGH) and disables (registered LOW) termination resistance internal to the DDR3L SDRAM. When enabled in normal operation, ODT is only applied to each of the following balls: DQ[7:0], DQS, DQS#, and DM for the x8; DQ[3:0], DQS, DQS#, and DM for the x4. The ODT input is ignored if disabled via the LOAD MODE command. ODT is referenced to VREFCA.

6.2.8 Power Rails

The DDR3L memory device and the DDR3 rails on the processor are supplied by the**TPS65217C**. Default voltage is 1.5V but can be scaled down to 1.35V if desired.

6.2.9 VREF

The VREF signal is generated from a voltage divider on the**VDDS_DDR** rail that powers the processor DDR rail and the DDR3L device itself. Figure 33 below shows the configuration of this signal and the connection to the DDR3L memory device and the processor.

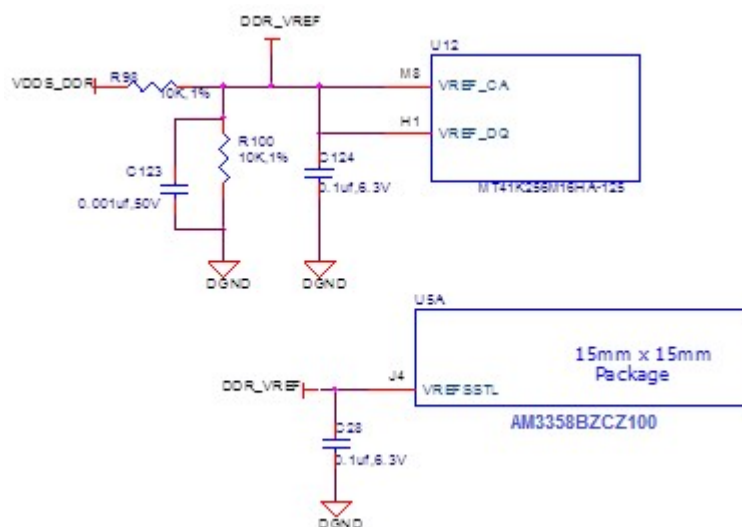

Fig. 6.14: DDR3L VREF Design

6.2.10 4GB eMMC Memory

The eMMC is a communication and mass data storage device that includes a Multi-MediaCard (MMC) interface, a NAND Flash component, and a controller on an advanced 11-signal bus, which is compliant with the MMC system specification. The nonvolatile eMMC draws no power to maintain stored data, delivers high performance across a wide range of operating temperatures, and resists shock and vibration disruption.

One of the issues faced with SD cards is that across the different brands and even within the same brand, performance can vary. Cards use different controllers and different memories, all of which can have bad locations that the controller handles. But the controllers may be optimized for reads or writes. You never know what you will be getting. This can lead to varying rates of performance. The eMMC card is a known controller and when coupled with the 8bit mode, 8 bits of data instead of 4, you get double the performance which should result in quicker boot times.

The following sections describe the design and device that is used on the board to implement this interface.

6.2.11 eMMC Device

The device used is one of two different devices:

- Micron *MTFC4GLDEA 0M WT*
- Kingston *KE4CN2H5A-A58*

The package is a 153 ball WFBGA device on both devices.

6.2.12 eMMC Circuit Design

figure-34 is the design of the eMMC circuitry. The eMMC device is connected to the MMC1 port on the processor. MMC0 is still used for the microSD card as is currently done on the original BeagleBone. The size of the eMMC supplied is now 4GB.

The device runs at 3.3V both internally and the external I/O rails. The VCCI is an internal voltage rail to the device. The manufacturer recommends that a 1uF capacitor be attached to this rail, but a 2.2uF was chosen to provide a little margin.

Pullup resistors are used to increase the rise time on the signals to compensate for any capacitance on the board.

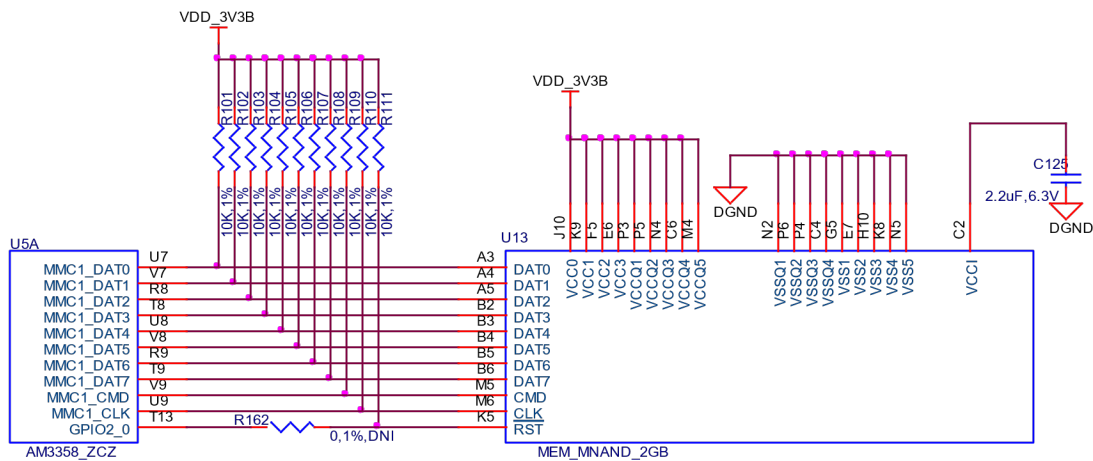

Fig. 6.15: eMMC Memory Design

The pins used by the eMMC1 in the boot mode are listed below in Table 6.

Signal name	Pin Used in Device
clk	gpmc_csn1
cmd	gpmc_csn2
dat0	gpmc_ad0
dat1	gpmc_ad1
dat2	gpmc_ad2
dat3	gpmc_ad3

Fig. 6.16: eMMC Boot Pins

For eMMC devices the ROM will only support raw mode. The ROM Code reads out raw sectors from image or the booting file within the file system and boots from it. In raw mode the booting image can be located at one of the four consecutive locations in the main area: offset 0x0 / 0x20000 (128 KB) / 0x40000 (256 KB) / 0x60000 (384 KB). For this reason, a booting image shall not exceed 128KB in size. However it is possible to flash a device with an image greater than 128KB starting at one of the aforementioned locations. Therefore

the ROM Code does not check the image size. The only drawback is that the image will cross the subsequent image boundary. The raw mode is detected by reading sectors #0, #256, #512, #768. The content of these sectors is then verified for presence of a TOC structure. In the case of a *GP Device*, a Configuration Header (CH)*must* be located in the first sector followed by a *GP header*. The CH might be void (only containing a CHSETTINGS item for which the Valid field is zero).

The ROM only supports the 4-bit mode. After the initial boot, the switch can be made to 8-bit mode for increasing the overall performance of the eMMC interface.

6.2.13 Board ID EEPROM

The BeagleBone is equipped with a single 32Kbit(4KB) 24LC32AT-I/OT EEPROM to allow the SW to identify the board. *Table 7* below defined the contents of the EEPROM.

Table 6.4: EEPROM Contents

Name	Size (bytes)	Contents
Header	4	0xAA, 0x55, 0x33, EE
Board Name	8	Name for board in ASCII: A335BNLT
Version	4	Hardware version code for board in ASCII: 00A3 for Rev A3, 00A4 for Rev A4, 00A5 for Rev A5, 00A6 for Rev A6, 00B0 for Rev B, and 00C0 for Rev C.
Serial Number	12	Serial number of the board. This is a 12 character string which is: WWYY4P16nnnn where, WW = 2 digit week of the year of production YY = 2 digit year of production BBBK = BeagleBone Black nnnn = incrementing board number
Configuration Option	32	Codes to show the configuration setup on this board. All FF
RSVD	6	FF FF FF FF FF FF
RSVD	6	FF FF FF FF FF FF
RSVD	6	FF FF FF FF FF FF
Available	4018	Available space for other non-volatile codes/data

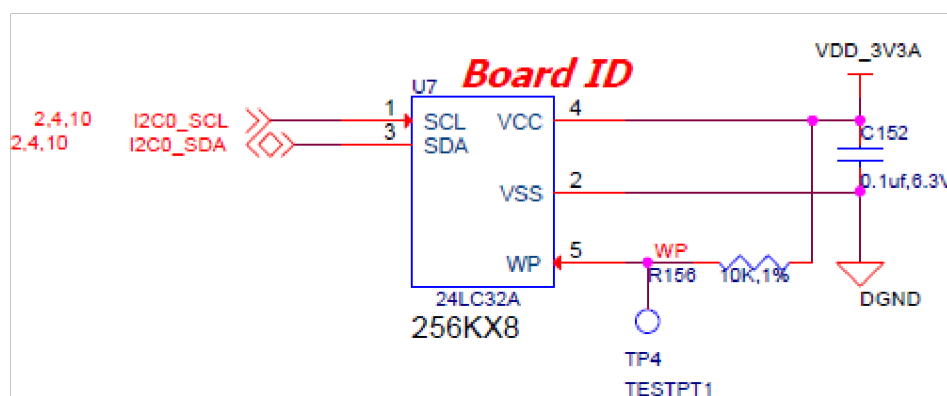

Fig. 6.17: EEPROM Design Rev A5

The EEPROM is accessed by the processor using the I2C 0 bus. The WP pin is enabled by default. By grounding the test point, the write protection is removed.

The first 48 locations should not be written to if you choose to use the extras storage space in the EEPROM for other purposes. If you do, it could prevent the board from booting properly as the SW uses this information to determine how to set up the board.

Micro Secure Digital

The microSD connector on the board will support a microSD card that can be used for booting or file storage on the BeagleBone Black.

6.2.14 microSD Design

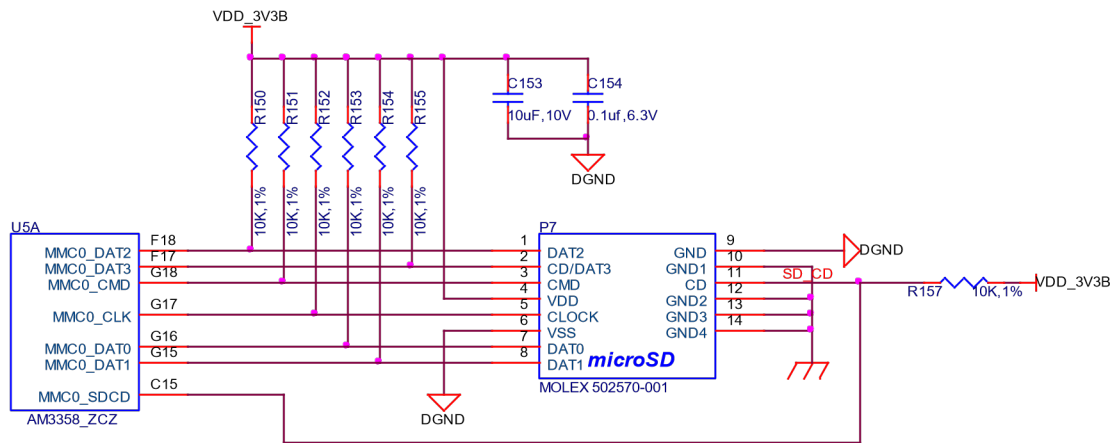

Fig. 6.18: microSD Design

The signals *MMC0-3* are the data lines for the transfer of data between the processor and the microSD connector.

The *MMC0_CLK* signal clocks the data in and out of the microSD card.

The *MMC0_CMD* signal indicates that a command versus data is being sent.

There is no separate card detect pin in the microSD specification. It uses *MMC0_DAT3* for that function. However, most microSD connectors still supply a CD function on the connectors. In the BeagleBone Black design, this pin is connected to the **MMC0_SDCD** pin for use by the processor. You can also change the pin to *GPIO0_6*, which is able to wake up the processor from a sleep mode when an microSD card is inserted into the connector.

Pullup resistors are provided on the signals to increase the rise times of the signals to overcome PCB capacitance.

Power is provided from the *VDD_3V3B* rail and a 10uF capacitor is provided for filtering.

6.3 6.6 User LEDs

There are four user LEDs on the BeagleBone Black. These are connected to GPIO pins on the processor. *Figure 37* shows the interfaces for the user LEDs.

Resistors R71-R74 were changed to 4.75K on the revision A5B and later boards.

Table 6.5: User LED Control Signals/Pins

LED	GPIO SIGNAL	PROC PIN
USR0	GPIO1_21	V15
USR1	GPIO1_22	U15
USR2	GPIO1_23	T15
USR3	GPIO1_24	V16

A logic level of “1” will cause the LEDs to turn on.

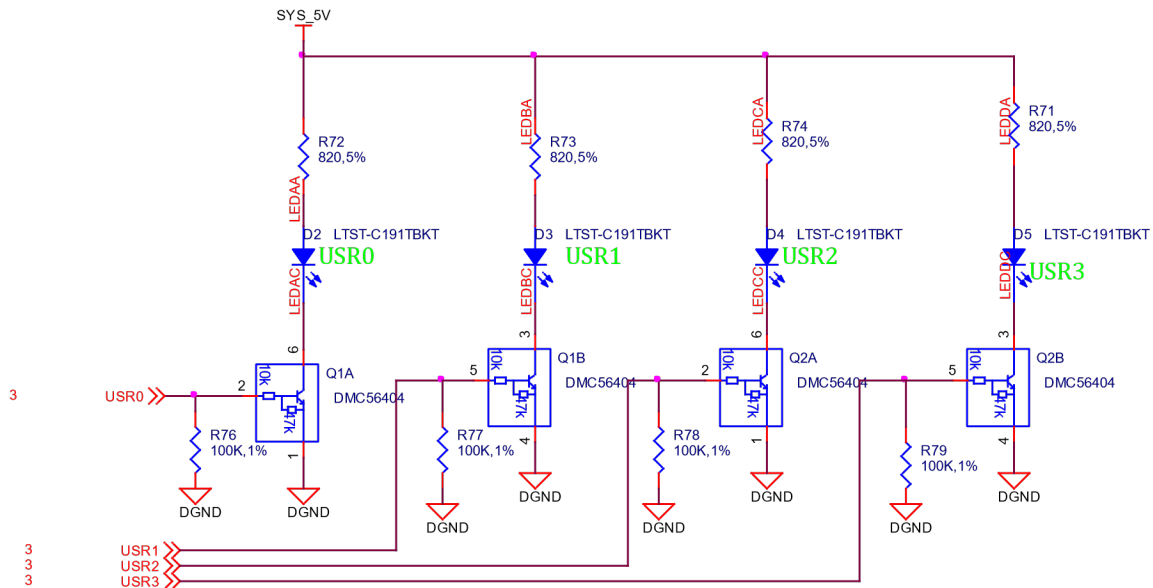

Fig. 6.19: User LEDs

6.3.1 Boot Configuration

The design supports two groups of boot options on the board. The user can switch between these modes via the Boot button. The primary boot source is the onboard eMMC device. By holding the Boot button, the user can force the board to boot from the microSD slot. This enables the eMMC to be overwritten when needed or to just boot an alternate image. The following sections describe how the boot configuration works.

In most applications, including those that use the provided demo distributions available from beagleboard.org the processor-external boot code is composed of two stages. After the primary boot code in the processor ROM passes control, a secondary stage (secondary program loader – “SPL” or “MLO”) takes over. The SPL stage initializes only the required devices to continue the boot process, and then control is transferred to the third stage “U-boot”. Based on the settings of the boot pins, the ROM knows where to go and get the SPL and UBoot code. In the case of the BeagleBone Black, that is either eMMC or microSD based on the position of the boot switch.

6.3.2 Boot Configuration Design

figure-38 shows the circuitry that is involved in the boot configuration process. On power up, these pins are read by the processor to determine the boot order. S2 is used to change the level of one bit from HI to LO which changes the boot order.

It is possible to override these setting via the expansion headers. But be careful not to add too much load such that it could interfere with the operation of the HDMI interface or LCD panels. If you choose to override these settings, it is strongly recommended that you gate these signals with the `SYS_RESETn` signal. This ensures that after coming out of reset these signals are removed from the expansion pins.

6.3.3 Default Boot Options

Based on the selected option found in figure-39 below, each of the boot sequences for each of the two settings is shown.

The first row in «figure-39» is the default setting. On boot, the processor will look for the eMMC on the MMC1 port first, followed by the microSD slot on MMC0, USB0 and UART0. In the event there is no microSD card and the eMMC is empty, UART0 or USB0 could be used as the board source.

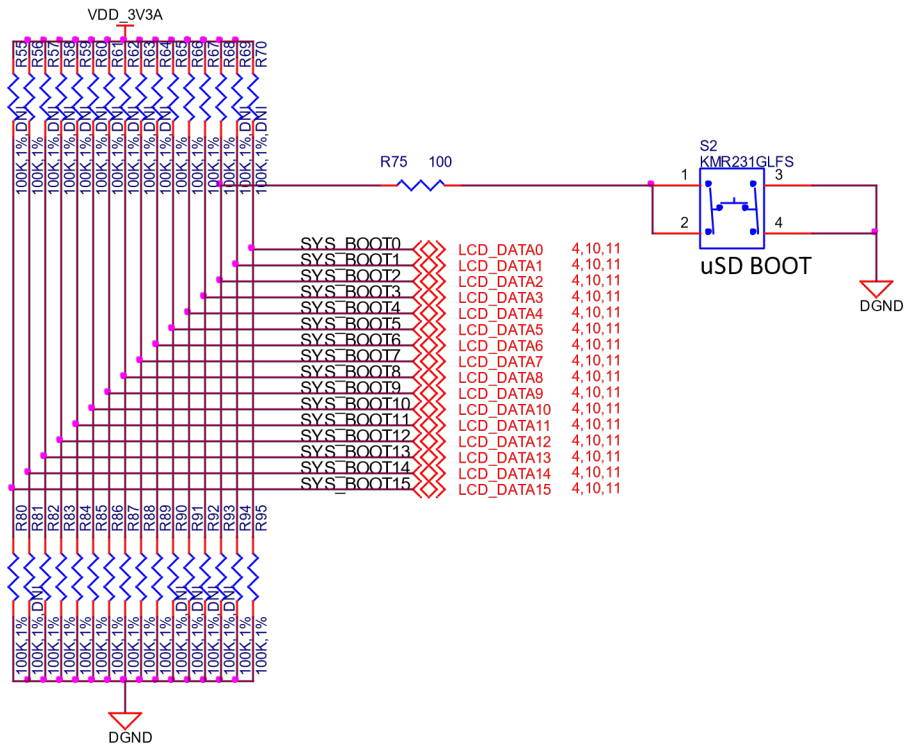

Fig. 6.20: Processor Boot Configuration Design

SYSBOOT[15:14]	SYSBOOT[13:12]	SYSBOOT[11:10]	SYSBOOT[9]	SYSBOOT[8]	SYSBOOT[7:6]	SYSBOOT[5]	SYSBOOT[4:0]	Boot Sequence			
00b = 19.2MHz 01b = 24MHz 10b = 25MHz 11b = 26MHz	00b (all other values reserved)	Don't care for ROM code	Don't care for ROM code	Don't care for ROM code	Don't care for ROM code	0 = CLKOUT1 disabled 1 = CLKOUT1 enabled	11100b	MMC1	MMC0	UART0	USB0[5]
00b = 19.2MHz 01b = 24MHz 10b = 25MHz 11b = 26MHz	00b (all other values reserved)	Don't care for ROM code	Don't care for ROM code	Don't care for ROM code	Don't care for ROM code	0 = CLKOUT1 disabled 1 = CLKOUT1 enabled	11000b	SPI0	MMC0	USB0[5] 1	UART0

Fig. 6.21: Processor Boot Configuration

If you have a microSD card from which you need to boot from, hold the boot button down. On boot, the processor will look for the SPIO0 port first, then microSD on the MMC0 port, followed by USB0 and UART0. In the event there is no microSD card and the eMMC is empty, USB0 or UART0 could be used as the board source.

6.4 10/100 Ethernet

The BeagleBone Black is equipped with a 10/100 Ethernet interface. It uses the same PHY as is used on the original BeagleBone. The design is described in the following sections.

6.4.1 Ethernet Processor Interface

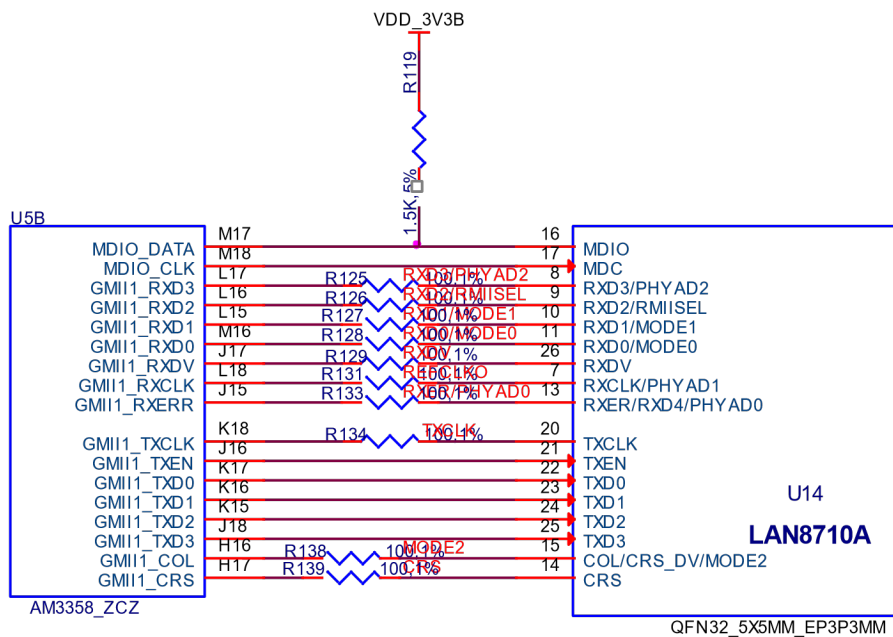

Fig. 6.22: Ethernet Processor Interface

This is the same interface as is used on the BeagleBone. No changes were made in this design for the board.

6.4.2 Ethernet Connector Interface

The off board side of the PHY connections are shown in *Figure 41* below.

This is the same interface as is used on the BeagleBone. No changes were made in this design for the board.

6.4.3 Ethernet PHY Power, Reset, and Clocks

VDD_3V3B Rail

The VDD_3V3B rail is the main power rail for the LAN8710A. It originates at the VD_3V3B regulator and is the primary rail that supports all of the peripherals on the board. This rail also supplies the VDDIO rails which set the voltage levels for all of the I/O signals between the processor and the LAN8710A.

VDD_PHYA Rail

A filtered version of VDD_3V3B rail is connected to the VDD rails of the LAN8710 and the termination resistors on the Ethernet signals. It is labeled as VDD_PHYA. The filtering inductor helps block transients that may be seen on the VDD_3V3B rail.

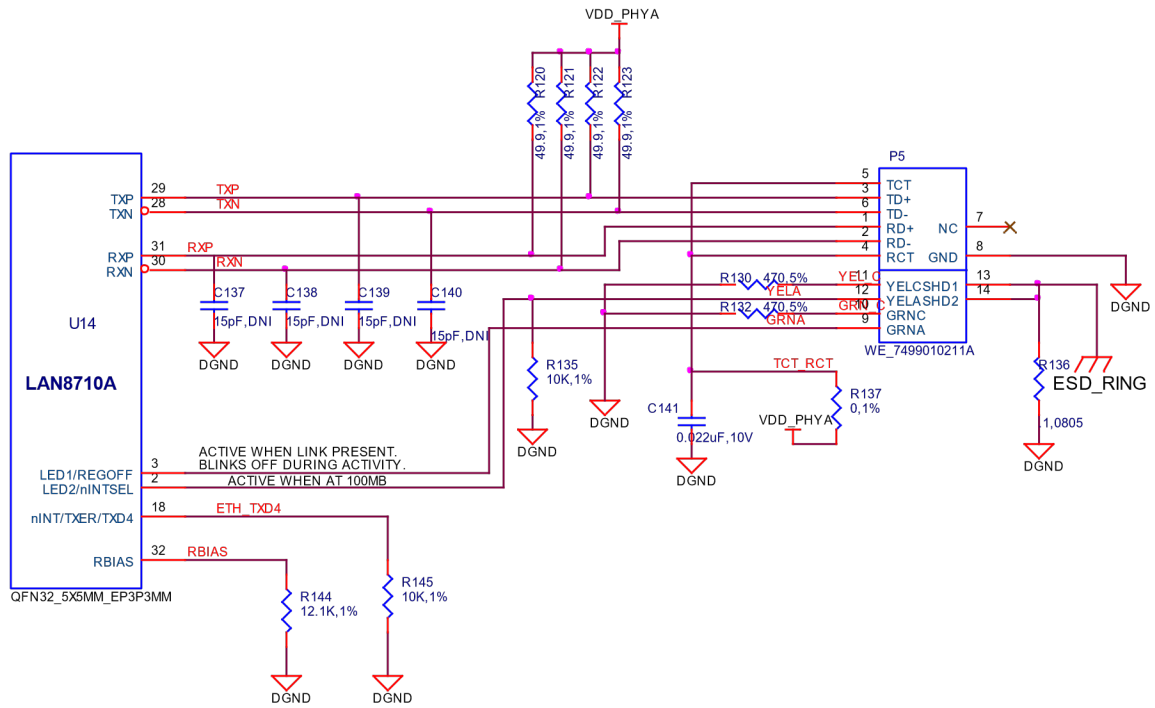

Fig. 6.23: Ethernet Connector Interface

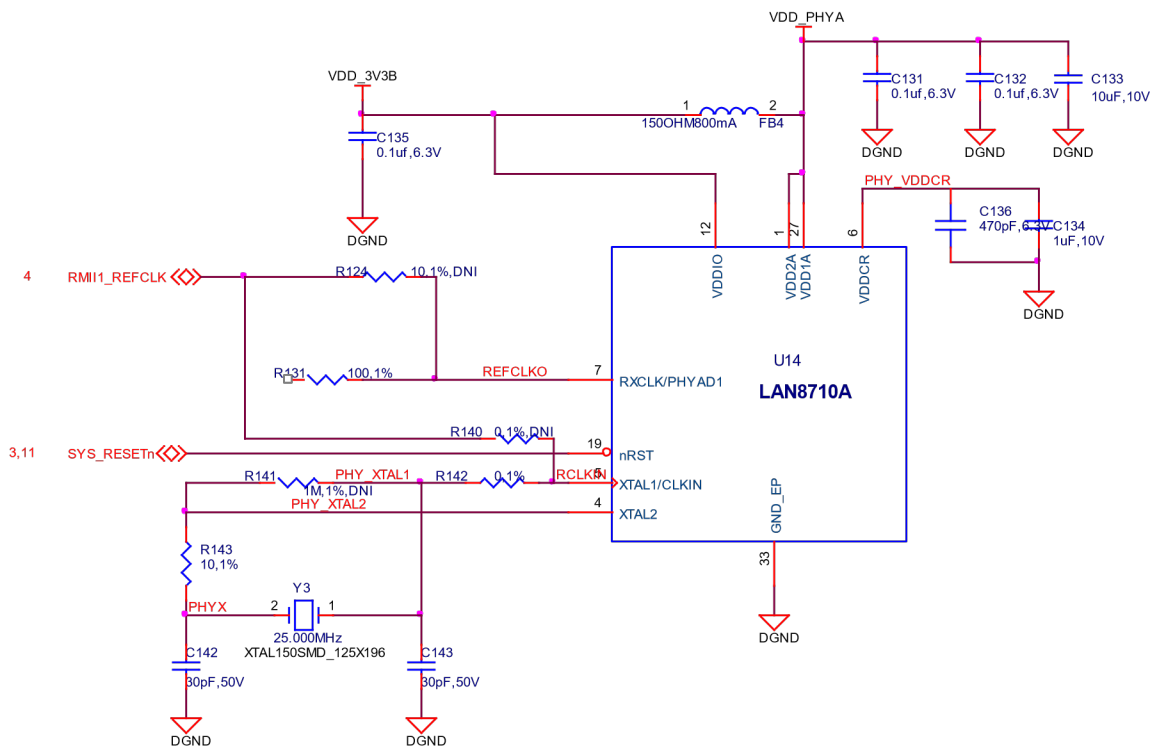

Fig. 6.24: Ethernet PHY, Power, Reset, and Clocks

PHY_VDDCR Rail

The *PHY_VDDCR* rail originates inside the LAN8710A. Filter and bypass capacitors are used to filter the rail. Only circuitry inside the LAN8710A uses this rail.

SYS_RESET

The reset of the LAN8710A is controlled via the *SYS_RESETn* signal, the main board reset line.

Clock Signals

A crystal is used to create the clock for the LAN8710A. The processor uses the *RMII_RXCLK* signal to provide the clocking for the data between the processor and the LAN8710A.

6.5 LAN8710A Mode Pins

There are mode pins on the LAN8710A that sets the operational mode for the PHY when coming out of reset. These signals are also used to communicate between the processor and the LAN8710A. As a result, these signals can be driven by the processor which can cause the PHY not to be initialized correctly. To ensure that this does not happen, three low value pull up resistors are used. *Figure 43* below shows the three mode pin resistors.

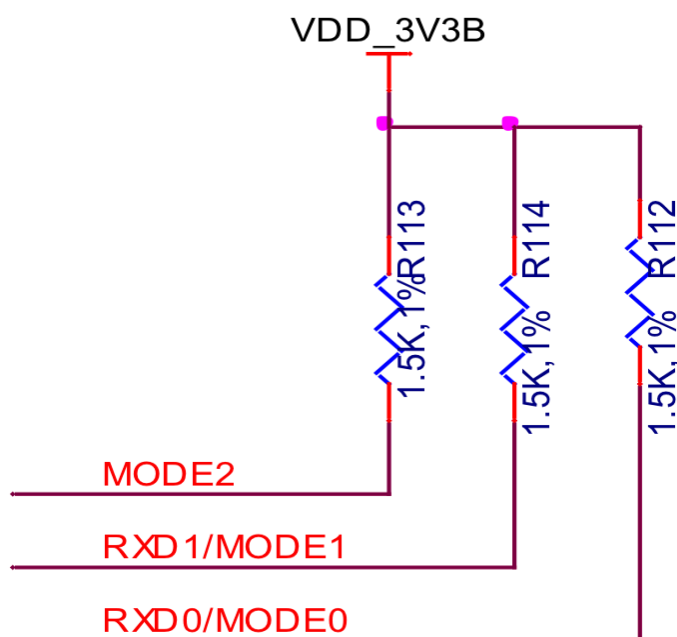

Fig. 6.25: Ethernet PHY Mode Pins

This will set the mode to be 111, which enables all modes and enables auto-negotiation.

6.6 HDMI Interface

The BeagleBone Black has an onboard HDMI framer that converts the LCD signals and audio signals to drive a HDMI monitor. The design uses an NXP *TDA19988* HDMI Framer.

The following sections provide more detail into the design of this interface.

6.6.1 Supported Resolutions

The maximum resolution supported by the BeagleBone Black is 1280x1024 @ 60Hz. *Table 9* below shows the supported resolutions. Not all resolutions may work on all monitors, but these have been tested and shown to work on at least one monitor. EDID is supported on the BeagleBone Black. Based on the EDID reading from the connected monitor, the highest compatible resolution is selected.

Table 6.6: HDMI Supported Monitor Resolutions

RESOLUTION	AUDIO
800 x 600 @60Hz	
800 x 600 @56Hz	
640 x 480 @75Hz	
640 x 480 @60Hz	YES
720 x 400 @70Hz	
1280 x 1024 @75Hz	
1024 x 768 @75Hz	
1024 x 768 @70Hz	
1024 x 768 @60Hz	
800 x 600 @75Hz	
800 x 600 @72Hz	
720 x 480 @60Hz	YES
1280 x 720 @60Hz	YES
1920 x 1080 @24Hz	YES

NOTE: The updated software image used on the Rev A5B and later boards added support for [1920x1080@24HZ](#).

Audio is limited to CEA supported resolutions. LCD panels only activate the audio in CEA modes. This is a function of the specification and is not something that can be fixed on the board via a hardware change or a software change.

6.6.2 HDMI Framer

The *TDA19988* is a High-Definition Multimedia Interface (HDMI) 1.4a transmitter. It is backward compatible with DVI 1.0 and can be connected to any DVI 1.0 or HDMI sink. The HDCP mode is not used in the design. The non-HDCP version of the device is used in the BeagleBone Black design.

This device provides additional embedded features like CEC (Consumer Electronic Control). CEC is a single bidirectional bus that transmits CEC over the home appliance network connected through this bus. This eliminates the need of any additional device to handle this feature. While this feature is supported in this device, as of this point, the SW to support this feature has not been implemented and is not a feature that is considered critical. It can be switched to very low power Standby or Sleep modes to save power when HDMI is not used. *TDA19988* embeds I²C-bus master interface for DDC-bus communication to read EDID. This device can be controlled or configured via I²C-bus interface.

6.6.3 HDMI Video Processor Interface

The *Figure 44* shows the connections between the processor and the HDMI framer device. There are 16 bits of display data, 5-6-5 that is used to drive the framer. The reason for 16 bits is that allows for compatibility with display and LCD capes already available on the original BeagleBone. The unused bits on the **TDA19988** are tied low. In addition to the data signals are the VSYNC, HSYNC, DE, and PCLK signals that round out the video interface from the processor.

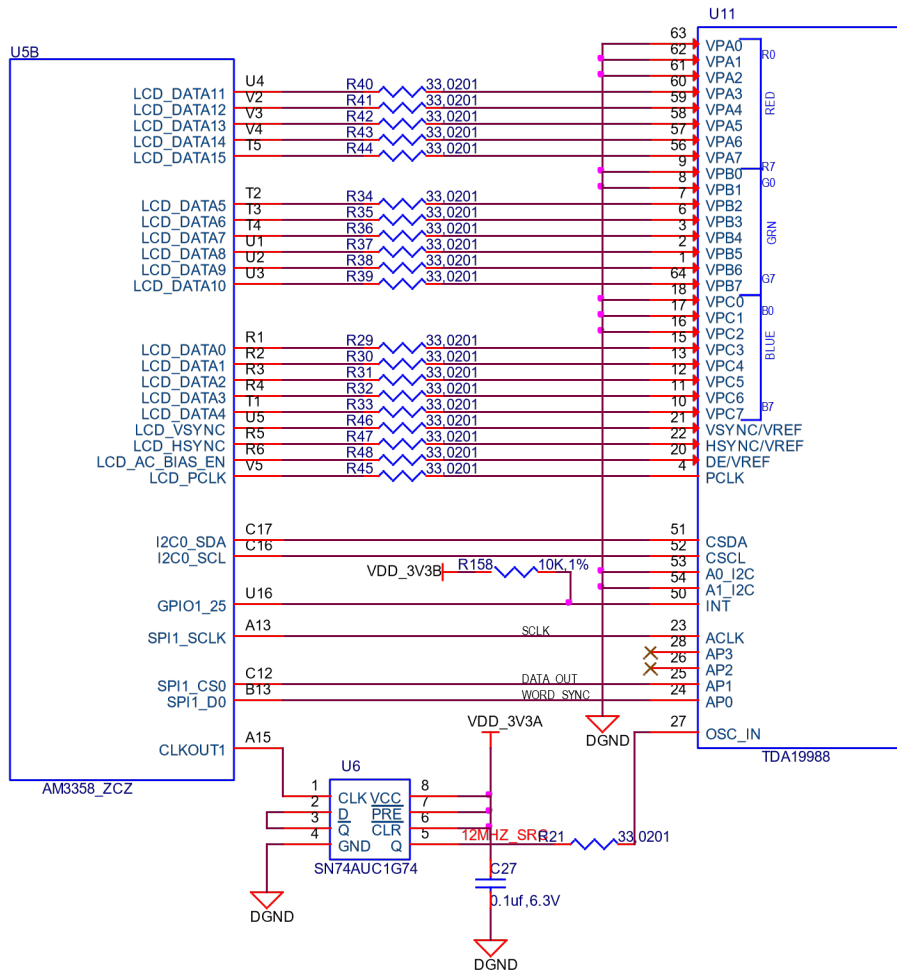

Fig. 6.26: HDMI Framer Processor Interface

6.6.4 HDMI Control Processor Interface

In order to use the *TDA19988*, the processor needs to setup the device. This is done via the I2C interface between the processor and the **TDA19988**. There are two signals on the *TDA19988* that could be used to set the address of the *TDA19988*. In this design they are both tied low. The I2C interface supports both 400kHz and 100kHz operation. *Table 10* shows the I2C address.

HDMI core address							
A6	A5	A4	A3	A2	A1	A0	R/W
1	1	1	0	0	X ^[1]	X ^[1]	0/1

Fig. 6.27: TDA19988 I2C Address

6.6.5 Interrupt Signal

There is a HDMI_INT signal that connects from the *TDA19988* to the processor. This signal can be used to alert the processor in a state change on the HDMI interface.

6.6.6 Audio Interface

There is an I2S audio interface between the processor and the *TDA19988*. Stereo audio can be transported over the HDMI interface to an audio equipped display. In order to create the required clock frequencies, an external 24.576MHz oscillator,*Y4*, is used. From this clock, the processor generates the required clock frequencies for the *TDA19988*.

There are three signals used to pass data from the processor to the *TDA19988*. SCLK is the serial clock. SPI1_CS0 is the data pin to the **TDA19988**. SPI1_D0 is the word sync pin. These signals are configured as I2S interfaces.

Audio is limited to CEA supported resolutions. LCD panels only activate the audio in CEA modes. This is a function of the specification and is not something that can be fixed on the board via a hardware change or a software change.

In order to create the correct clock frequencies, we had to add an external 24.576MHz oscillator. Unfortunately this had to be input into the processor using the pin previously used for **GPIO3_21**. In order to keep GPIO3_21 functionality, we provided a way to disable the oscillator if the need was there to use the pin on the expansion header. *Figure 45* shows the oscillator circuitry.

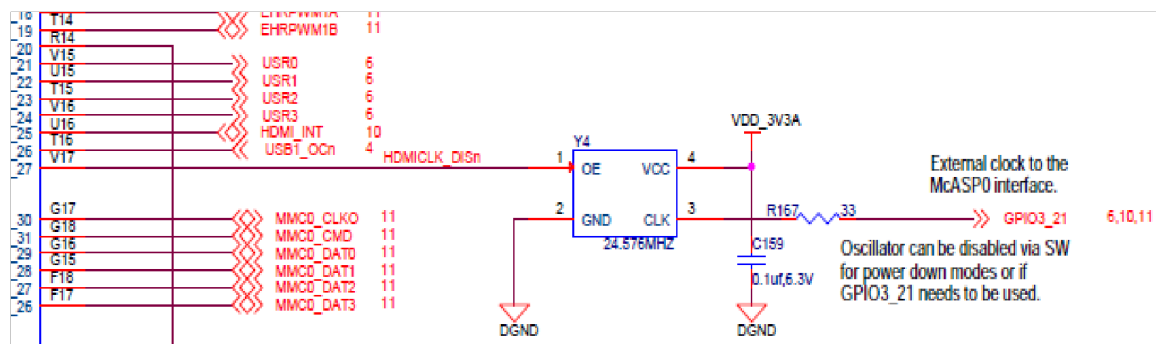

Fig. 6.28: 24.576MHZ Oscillator

6.6.7 Power Connections

figure-46 shows the power connections to the **TDA19988** device. All voltage rails for the device are at 1.8V. A filter is provided to minimize any noise from the 1.8V rail getting back into the device.

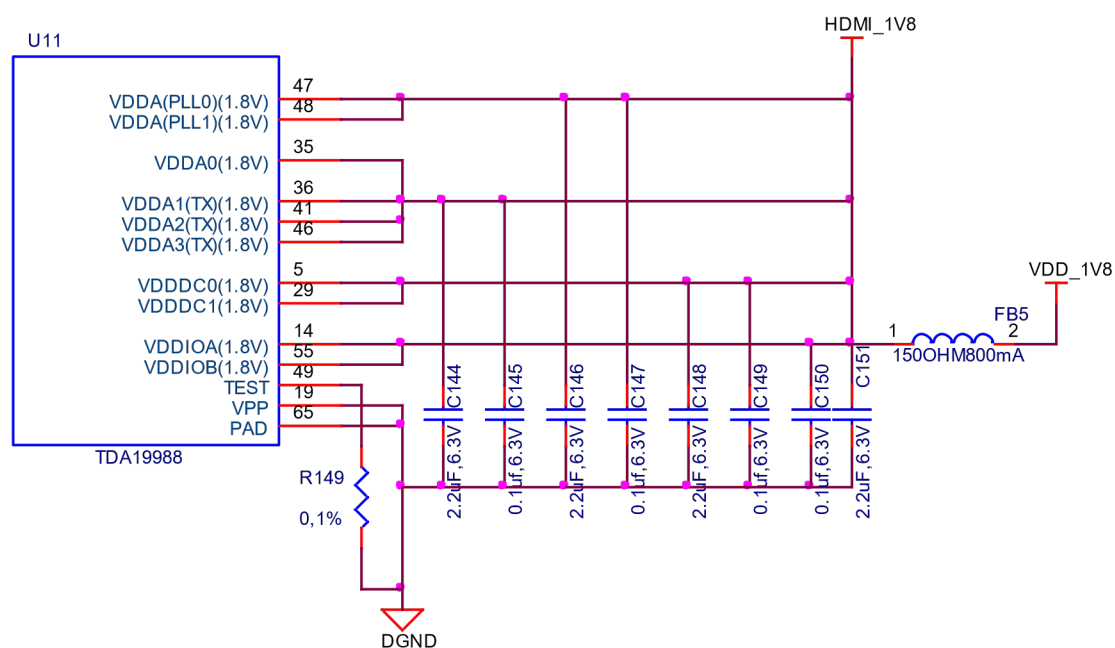

Fig. 6.29: HDMI Power Connections

All of the interfaces between the processor and the *TDA19988* are 3.3V tolerant allowing for direct connection.

6.6.8 HDMI Connector Interface

figure-47 shows the design of the interface between the HDMI Framer and the connector.

The connector for the HDMI interface is a microHDMI. It should be noted that this connector has a different pinout than the standard or mini HDMI connectors. D6 and D7 are ESD protection devices.

6.7 USB Host

The board is equipped with a single USB host interface accessible from a single USB Type A female connector. «figure-48» is the design of the USB Host circuitry.

6.7.1 Power Switch

U8 is a switch that allows the power to the connector to be turned on or off by the processor. It also has an over current detection that can alert the processor if the current gets too high via the **USB1_OC** signal. The power is controlled by the *USB1_DRVBUS* signal from the processor.

6.7.2 ESD Protection

U9 is the ESD protection for the signals that go to the connector.

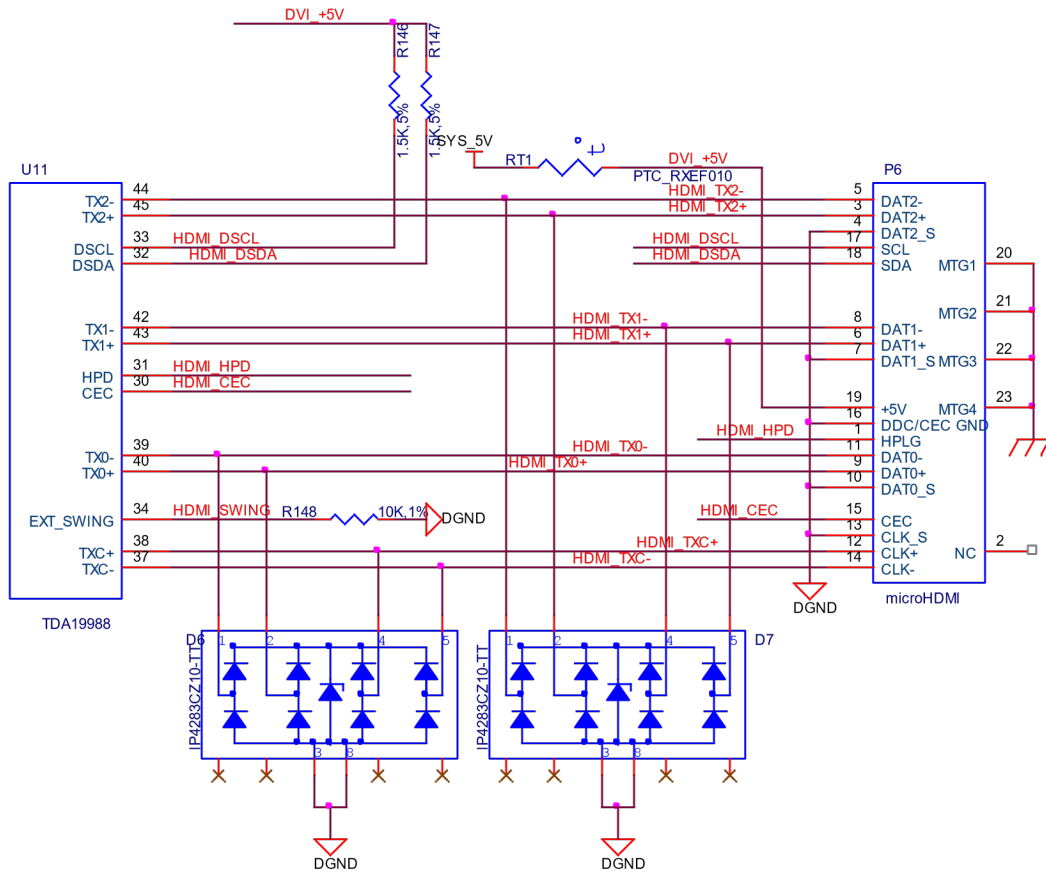

Fig. 6.30: Connector Interface Circuitry

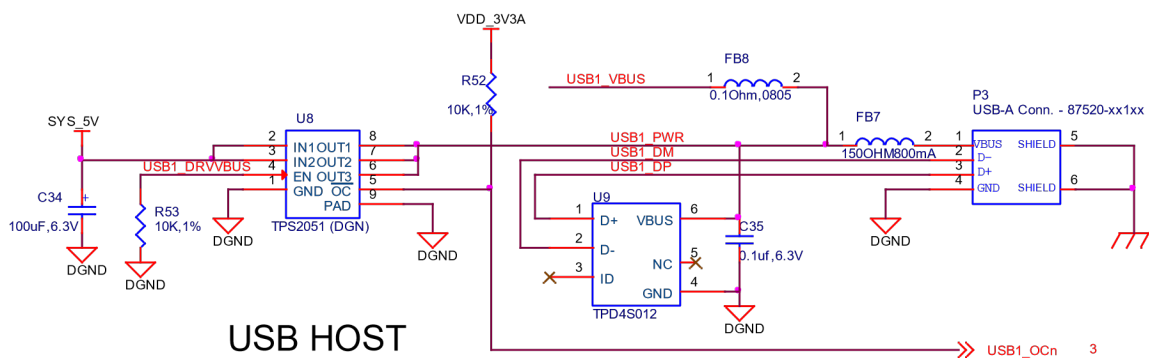

Figure 48. USB Host Circuitry

Fig. 6.31: USB Host circuit

6.7.3 Filter Options

FB7 and *FB8* were added to assist in passing the FCC emissions test. The *USB1_VBUS* signal is used by the processor to detect that the 5V is present on the connector. *FB7* is populated and *FB8* is replaced with a .1 ohm resistor.

6.8 PRU-ICSS

The PRU-ICSS module is located inside the AM3358 processor. Access to these pins is provided by the expansion headers and is multiplexed with other functions on the board. Access is not provided to all of the available pins.

All documentation is located at http://github.com/beagleboard/am335x_pru_package_

This feature is not supported by Texas Instruments.

6.8.1 PRU-ICSS Features

The features of the PRU-ICSS include:

Two independent programmable real-time (PRU) cores:

- 32-Bit Load/Store RISC architecture
- 8K Byte instruction RAM (2K instructions) per core
- 8K Bytes data RAM per core
- 12K Bytes shared RAM
- Operating frequency of 200 MHz
- PRU operation is little endian similar to ARM processor
- All memories within PRU-ICSS support parity
- Includes Interrupt Controller for system event handling
- Fast I/O interface

16 input pins and 16 output pins per PRU core. *(Not all of these are accessible on the BeagleBone Black).*

6.8.2 PRU-ICSS Block Diagram

6.8.3 PRU-ICSS Pin Access

Both PRU 0 and PRU1 are accessible from the expansion headers. Some may not be usable without first disabling functions on the board like LCD for example. Listed below is what ports can be accessed on each PRU.

- 8 outputs or 9 inputs
- 13 outputs or 14 inputs
- UART0_TXD, UART0_RXD, UART0_CTS, UART0_RTS

Table 6.7: P8 PRU0 and PRU1 Access

PIN	PROC	NAME	
11	R12	GPIO1_13	pr1_pru0_pru_r30_15 (Output)

continues on next page

Table 6.7 – continued from previous page

PIN	PROC	NAME		
12	T12	GPIO1_12		pr1_pru0_pru_r30_14 (Output)
15	U13	GPIO1_15		pr1_pru0_pru_r31_15 (Input)
16	V13	GPIO1_14		pr1_pru0_pru_r31_14 (Input)
20	V9	GPIO1_31	pr1_pru1_pru_r30_13 (Output)	pr1_pru1_pru_r31_13 (INPUT)
21	U9	GPIO1_30	pr1_pru1_pru_r30_12 (Output)	pr1_pru1_pru_r31_12 (INPUT)
27	U5	GPIO2_22	pr1_pru1_pru_r30_8 (Output)	pr1_pru1_pru_r31_8 (INPUT)
28	V5	GPIO2_24	pr1_pru1_pru_r30_10 (Output)	pr1_pru1_pru_r31_10 (INPUT)
29	R5	GPIO2_23	pr1_pru1_pru_r30_9 (Output)	pr1_pru1_pru_r31_9 (INPUT)
39	T3	GPIO2_12	pr1_pru1_pru_r30_6 (Output)	pr1_pru1_pru_r31_6 (INPUT)
40	T4	GPIO2_13	pr1_pru1_pru_r30_7 (Output)	pr1_pru1_pru_r31_7 (INPUT)
41	T1	GPIO2_10	pr1_pru1_pru_r30_4 (Output)	pr1_pru1_pru_r31_4 (INPUT)
42	T2	GPIO2_11	pr1_pru1_pru_r30_5 (Output)	pr1_pru1_pru_r31_5 (INPUT)
43	R3	GPIO2_8	pr1_pru1_pru_r30_2 (Output)	pr1_pru1_pru_r31_2 (INPUT)
44	R4	GPIO2_9	pr1_pru1_pru_r30_3 (Output)	pr1_pru1_pru_r31_3 (INPUT)
45	R1	GPIO2_6	pr1_pru1_pru_r30_0 (Output)	pr1_pru1_pru_r31_0 (INPUT)
46	R2	GPIO2_7	pr1_pru1_pru_r30_1 (Output)	pr1_pru1_pru_r31_1 (INPUT)

Table 6.8: P9 PRU0 and PRU1 Access

PIN	PROC	NAME			
17	A16	I2C1_SCL	pr1_uart0_txd		
18	B16	I2C1_SDA	pr1_uart0_rxd		
19	D17	I2C2_SCL	pr1_uart0_rts_n		
20	D18	I2C2_SDA	pr1_uart0_cts_n		
21	B17	UART2_TXD	pr1_uart0_rts_n		
22	A17	UART2_RXD	pr1_uart0_cts_n		
24	D15	UART1_TXD	pr1_uart0_txd	pr1_pru0_pru_r31_16 (Input)	
25	A14	GPIO3_21	pr1_pru0_pru_r30_5 (Output)	pr1_pru0_pru_r31_5 (Input)	
26	D16	UART1_RXD	pr1_uart0_rxd	pr1_pru1_pru_r31_16	
27	C13	GPIO3_19	pr1_pru0_pru_r30_7 (Output)	pr1_pru0_pru_r31_7 (Input)	
28	C12	SPI1_CS0	eCAP2_in_PWM2_out	pr1_pru0_pru_r30_3 (Output)	pr1_pru0_pru_r31_3 (Input)
29	B13	SPI1_D0	pr1_pru0_pru_r30_1 (Output)	pr1_pru0_pru_r31_1 (Input)	

continues on next page

Table 6.8 – continued from previous page

PIN	PROC	NAME		
30	D12	SPI1_D1	pr1_pru0_pru_r30_2 (Output)	pr1_pru0_pru_r31_2 (Input)
31	A13	SPI1_SCLK	pr1_pru0_pru_r30_0 (Output)	pr1_pru0_pru_r31_0 (Input)

Note: GPIO3_21 is also the 24.576MHZ clock input to the processor to enable HDMI audio. To use this pin the oscillator must be disabled.

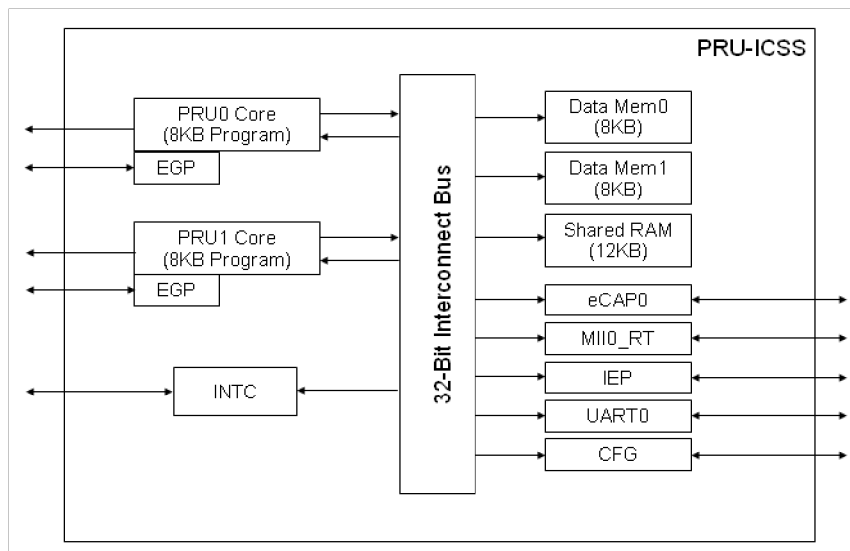

Fig. 6.32: PRU-ICSS Block Diagram

Chapter 7

Connectors

This section describes each of the connectors on the board.

7.1 Expansion Connectors

The expansion interface on the board is comprised of two 46 pin connectors. All signals on the expansion headers are `_3.3V_` unless otherwise indicated.

NOTE: Do not connect 5V logic level signals to these pins or the board will be damaged.

NOTE: DO NOT APPLY VOLTAGE TO ANY I/O PIN WHEN POWER IS NOT SUPPLIED TO THE BOARD. IT WILL DAMAGE THE PROCESSOR AND VOID THE WARRANTY.

NO PINS ARE TO BE DRIVEN UNTIL AFTER THE SYS_RESET LINE GOES HIGH.

The location and spacing of the expansion headers are the same as on the original BeagleBone.

7.1.1 Connector P8

table-12 shows the pinout of the **P8** expansion header. Other signals can be connected to this connector based on setting the pin mux on the processor, but this is the default settings on power up. The SW is responsible for setting the default function of each pin. There are some signals that have not been listed here. Refer to the processor documentation for more information on these pins and detailed descriptions of all of the pins listed. In some cases there may not be enough signals to complete a group of signals that may be required to implement a total interface.

The *PROC* column is the pin number on the processor.

The *PIN* column is the pin number on the expansion header.

The *MODE* columns are the mode setting for each pin. Setting each mode to align with the mode column will give that function on that pin.

NOTE: DO NOT APPLY VOLTAGE TO ANY I/O PIN WHEN POWER IS NOT SUPPLIED TO THE BOARD. IT WILL DAMAGE THE PROCESSOR AND VOID THE WARRANTY.

NO PINS ARE TO BE DRIVEN UNTIL AFTER THE SYS_RESET LINE GOES HIGH.

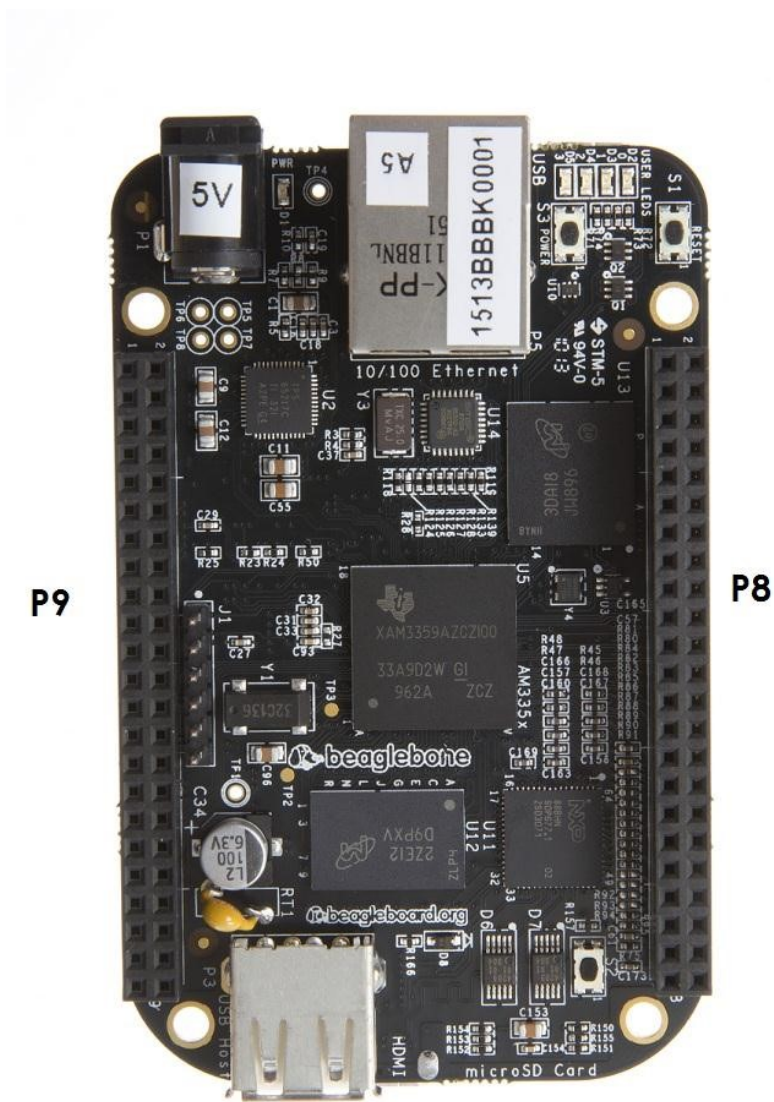

Fig. 7.1: Expansion Connector Location

Table 7.1: Expansion Header P8 Pinout

PIN	PROC	NAME	MODE0	MODE1	MODE2	MODE3	MODE4	MODE5	MODE6	MODE7
1,2		GND								
3	R9	GPIO1_6	gpmc_ad6	mmc1_dat6						gpio1[6]
4	T9	GPIO1_7	gpmc_ad7	mmc1_dat7						gpio1[7]
5	R8	GPIO1_2	gpmc_ad2	mmc1_dat2						gpio1[2]
6	T8	GPIO1_3	gpmc_ad3	mmc1_dat3						gpio1[3]
7	R7	TIMER4	gpmc_advn_ale		timer4					gpio2[2]
8	T7	TIMER7	gpmc_oen_ren		timer7					gpio2[3]
9	T6	TIMER5	gpmc_be0n_cle		timer5					gpio2[5]
10	U6	TIMER6	gpmc_wen		timer6					gpio2[4]
11	R12	GPIO1_13	gpmc_ad13	lcd_data18	mmc1_dat5	mmc2_dat1	eQEP2B_in		pr1_pru0_pru_r30_15	gpio1[13]
12	T12	GPIO1_12	gpmc_ad12	lcd_data19	mmc1_dat4	mmc2_dat0	eQEP2a_in		pr1_pru0_pru_r30_14	gpio1[12]
13	T10	EHRPWM2B	gpmc_ad9	lcd_data22	mmc1_dat1	mmc2_dat5	ehrpwm2B			gpio0[23]
14	T11	GPIO0_26	gpmc_ad10	lcd_data21	mmc1_dat2	mmc2_dat6	ehrpwm2_tripzone_in			gpio0[26]
15	U13	GPIO1_15	gpmc_ad15	lcd_data16	mmc1_dat7	mmc2_dat3	eQEP2_strobe		pr1_pru0_pru_r31_15	gpio1[15]
16	V13	GPIO1_14	gpmc_ad14	lcd_data17	mmc1_dat6	mmc2_dat2	eQEP2_index		pr1_pru0_pru_r31_14	gpio1[14]
17	U12	GPIO0_27	gpmc_ad11	lcd_data20	mmc1_dat3	mmc2_dat7	ehrpwm0_synco			gpio0[27]
18	V12	GPIO2_1	gpmc_clk_mux0	lcd_memory_clk	gpmc_wait1	mmc2_clk			mcaspo_fsr	gpio2[1]
19	U10	EHRPWM2A	gpmc_ad8	lcd_data23	mmc1_dat0	mmc2_dat4	ehrpwm2A			gpio0[22]
20	V9	GPIO1_31	gpmc_csn2	gpmc_be1n	mmc1_cmd			pr1_pru1_pru_r30_13	pr1_pru1_pru_r31_13	gpio1[31]
21	U9	GPIO1_30	gpmc_csn1	gpmc_clk				pr1_pru1_pru_r30_12	pr1_pru1_pru_r31_12	gpio1[30]
22	V8	GPIO1_5	gpmc_ad5	mmc1_dat5	mmc1_dat5					gpio1[5]
23	U8	GPIO1_4	gpmc_ad4	mmc1_dat4						gpio1[4]
24	V7	GPIO1_1	gpmc_ad1	mmc1_dat1						gpio1[1]
25	U7	GPIO1_0	gpmc_ad0	mmc1_dat0						gpio1[0]
26	V6	GPIO1_29	gpmc_csn0							gpio1[29]
27	U5	GPIO2_22	lcd_vsync	gpmc_a8						gpio2[22]
28	V5	GPIO2_24	lcd_pclk	gpmc_a10				pr1_pru1_pru_r30_8	pr1_pru1_pru_r31_8	gpio2[24]
29	R5	GPIO2_23	lcd_hsync	gpmc_a9				pr1_pru1_pru_r30_10	pr1_pru1_pru_r31_10	gpio2[23]
30	R6	GPIO2_25	lcd_ac_bias_en	gpmc_a11				pr1_pru1_pru_r30_9	pr1_pru1_pru_r31_9	gpio2[25]
31	V4	UART5_CTSN	lcd_data14	gpmc_a18	eQEP1_index	mcaspo_axr1	uart5_rxd		uart5_ctsn	gpio0[10]
32	T5	UART5_RTSN	lcd_data15	gpmc_a19	eQEP1_strobe	mcaspo_ahclkx	mcaspo_axr3		uart5_rtsn	gpio0[11]
33	V3	UART4_RTSN	lcd_data13	gpmc_a17	eQEP1B_in	mcaspo_fsr	mcaspo_axr3		uart4_rtsn	gpio0[9]
34	U4	UART3_RTSN	lcd_data11	gpmc_a15	ehrpwm1B	mcaspo_ahclkx	mcaspo_axr2		uart3_rtsn	gpio2[17]
35	V2	UART4_CTSN	lcd_data12	gpmc_a16	eQEP1A_in	mcaspo_aclkr	mcaspo_axr2		uart4_ctsn	gpio0[8]
36	U3	UART3_CTSN	lcd_data10	gpmc_a14	ehrpwm1A	mcaspo_axr0			uart3_ctsn	gpio2[16]
37	U1	UART5_TXD	lcd_data8	gpmc_a12	ehrpwm1_tripzone_in	mcaspo_aclcx	uart5_txd		uart2_ctsn	gpio2[14]
38	U2	UART5_RXD	lcd_data9	gpmc_a13	ehrpwm0_synco	mcaspo_fsx	uart5_rxd		uart2_rtsn	gpio2[15]
39	T3	GPIO2_12	lcd_data6	gpmc_a6	eQEP2_index	mcaspo_fsx		pr1_pru1_pru_r30_6	pr1_pru1_pru_r31_6	gpio2[12]
40	T4	GPIO2_13	lcd_data7	gpmc_a7	eQEP2_strobe	eQEP2_index		pr1_pru1_pru_r30_7	pr1_pru1_pru_r31_7	gpio2[13]
41	T1	GPIO2_10	lcd_data4	gpmc_a4	eQEP2A_in	eQEP2A_in	pr1_edio_data_out7		pr1_pru1_pru_r31_7	gpio2[10]
42	T2	GPIO2_11	lcd_data5	gpmc_a5	eQEP2B_in	eQEP2B_in		pr1_pru1_pru_r30_4	pr1_pru1_pru_r31_4	gpio2[11]
43	R3	GPIO2_8	lcd_data2	gpmc_a2	ehrpwm2_tripzone_in	ehrpwm2_tripzone_in		pr1_pru1_pru_r30_5	pr1_pru1_pru_r31_5	gpio2[8]
44	R4	GPIO2_9	lcd_data3	gpmc_a3	ehrpwm0_synco	ehrpwm0_synco		pr1_pru1_pru_r30_2	pr1_pru1_pru_r31_2	gpio2[9]
45	R1	GPIO2_6	lcd_data0	gpmc_a0	ehrpwm2A	ehrpwm2A		pr1_pru1_pru_r30_3	pr1_pru1_pru_r31_3	gpio2[6]
46	R2	GPIO2_7	lcd_data1	gpmc_a1	ehrpwm2B	ehrpwm2B		pr1_pru1_pru_r30_1	pr1_pru1_pru_r31_1	gpio2[7]

7.1.2 Connector P9

Table-13 lists the signals on connector **P9**. Other signals can be connected to this connector based on setting the pin mux on the processor, but this is the default settings on power up.

There are some signals that have not been listed here. Refer to the processor documentation for more information on these pins and detailed descriptions of all of the pins listed. In some cases there may not be enough signals to complete a group of signals that may be required to implement a total interface.

The *PROC* column is the pin number on the processor.

The *PIN* column is the pin number on the expansion header.

The *MODE* columns are the mode setting for each pin. Setting each mode to align with the mode column will give that function on that pin.

NOTES:

In the table are the following notations:

PWR_BUT is a 5V level as pulled up internally by the TPS65217C. It is activated by pulling the signal to GND.

NOTE: DO NOT APPLY VOLTAGE TO ANY I/O PIN WHEN POWER IS NOT SUPPLIED TO THE BOARD. IT WILL DAMAGE THE PROCESSOR AND VOID THE WARRANTY.

NO PINS ARE TO BE DRIVEN UNTIL AFTER THE SYS_RESET LINE GOES HIGH.

- Both of these signals connect to pin 41 of P11. Resistors are installed that allow for the GPIO3_20 connection to be removed by removing R221. The intent is to allow the SW to use either of these signals, one or the other, on pin 41. SW should set the unused pin in input mode when using the other pin. This allowed us to get an extra signal out to the expansion header.
- Both of these signals connect to pin 42 of P11. Resistors are installed that allow for the GPIO3_18 connection to be removed by removing R202. The intent is to allow the SW to use either of these signals, on pin 42. SW should set the unused pin in input mode when using the other pin. This allowed us to get an extra signal out to the expansion header.

Table 7.2: Expansion Header P9 Pinout

PIN	PROC	NAME	MODE0	MODE1	MODE2	MODE3	MODE4	MODE5	MODE6	MODE7
1,2	GND									
3,4	DC_3.3V									
5,6	VDD_5V									
7,8	SYS_5V									
9	PWR_BUT									
10	A10	SYS_RESETn								
11	T17	UART4_RXD	gpmc_wait0	mii2_crs	gpmc_csn4	rmi2_crs_dv	mmc1_sdcd	uart4_rxd_mux2		gpio0[30]
12	U18	GPIO1_28	gpmc_bei_n	mii2_col	gpmc_csn6	mmc2_dat3	gpmc_dir	mcasp0_aclkr_mux3		gpio1[28]
13	U17	UART4_TXD	gpmc_wpn	mii2_rxerr	gpmc_csn5	rmi2_rxerr	mmc2_sdcd	uart4_txd_mux2		gpio0[31]
14	U14	HRPWM1A	gpmc_a2	mii2_txd3	rgmi2_td3	mmc2_dat1	gpmc_a18	ehrpwm1A_mux1		gpio1[18]
15	R13	GPIO1_16	gpmc_a0	gmi2_txen	rgmi2_tcl	mii2_txen	gpmc_a16	ehrpwm1A_tripzone_input		gpio1[16]
16	T14	HRPWM1B	gpmc_a3	mii2_txd2	rgmi2_td2	mmc2_dat2	gpmc_a19	ehrpwm1B_mux1		gpio1[19]
17	A16	I2C1_SCL	spi0_cs0	mmc2_sdwp	I2C1_SCL	ehrpwm0_synci	pr1_uart0_txd			gpio0[5]
18	B16	I2C1_SDA	spi0_d1	mmc1_sdwp	I2C1_SDA	ehrpwm0_tripzone	pr1_uart0_rxd			gpio0[4]
19	D17	I2C2_SCL	uart1_rtsn	timer5	dcan0_fx	I2C2_SCL	spi1_cs1	pr1_uart0_rts_n		gpio0[13]
20	D18	I2C2_SDA	uart1_ctsn	timer6	dcan0_tx	I2C2_SDA	spi1_cs0	pr1_uart0_cts_n		gpio0[12]
21	B17	UART2_TXD	uart1_d0	uart2_txd	I2C2_SCL	ehrpwm0B	pr1_uart0_rts_n	EMU3_mux1		gpio0[3]
22	A17	UART2_RXD	spi0_sclk	uart2_rxd	I2C2_SDA	ehrpwm0A	pr1_uart0_cts_n	EMU2_mux1		gpio0[2]
23	V14	GPIO1_17	gpmc_a1	gmi2_rxdv	rgmi2_rxdv	mmc2_dat0	gpmc_a17	ehrpwm0_synco		gpio1[17]
24	D15	UART1_TXD	uart1_txd	mmc2_sdwp	dcan1_rx	I2C1_SCL	pr1_uart0_txd	pr1_pru0_pru_r31_16		gpio0[15]
25	A14	GPIO3_21	mcasp0_ahclkx	eQEP0_strobe	mcasp0_axr3	mcaspl_axr1	pr1_pru0_pru_r31_7	pr1_pru0_pru_r31_7		gpio3[21]
26	D16	UART1_RXD	uart1_rxd	mmc1_sdwp	dcan1_tx	I2C1_SDA	EMU4_mux2	pr1_pru0_pru_r31_16		gpio0[14]
27	C13	GPIO3_19	mcasp0_fsr	eQEP0B_in	mcasp0_axr3	mcaspl_fsx	EMU2_mux2	pr1_pru0_pru_r31_5		gpio3[19]
28	C12	SPI1_CS0	mcasp0_ahclk	ehrpwm0_in	mcasp0_axr2	spi1_cs0	eCAP2_in_PWM2_out	pr1_pru0_pru_r31_3		gpio3[17]
29	B13	SPI1_D0	mcasp0_fsx	ehrpwm0B	mcasp0_axr2	spi1_d0	mmc1_sdcd_mux1	pr1_pru0_pru_r31_1		gpio3[15]
30	D12	SPI1_D1	mcasp0_axr0	ehrpwm0_tripzone	spi1_d1	spi1_d1	mmc2_sdcd_mux1	pr1_pru0_pru_r31_2		gpio3[16]
31	A13	SPI1_SCLK	mcasp0_aclkr	ehrpwm0A	spi1_sclk	spi1_sclk	mmc0_sdcd_mux1	pr1_pru0_pru_r31_0		gpio3[14]
32	VADC									
33	C8	AIN4								
34	AGND									
35	A8	AIN6								
36	B8	AIN5								
37	B7	AIN2								
38	A7	AIN3								
39	B6	AIN0								
40	C7	AIN1								
41	D14	CLKOUT2	xdma_event_intr1	clkout2	tdclk	clkout2	timer7_mux1	pr1_pru0_pru_r31_16	EMU3_mux0	gpio0[20]
D13	GPIO3_20	mcasp0_axr1	eQEP0_index	mcasp1_axr0		mcasp1_axr0	emu3	pr1_pru0_pru_r31_6	pr1_pru0_pru_r31_6	gpio3[20]
C18	GPIO0_7	eCAP0_in_PWM0_out	uart3_txd	uart3_txd	spi1_cs1	pr1_ecap0_ecap_capin_apwm_o	mmc0_sdwp	mmc0_sdwp	xdma_event_intr2	gpio0[7]
B12	GPIO3_18	mcasp0_aclkr	eQEP0A_in	eQEP0A_in	mcasp0_axr2	mcasp1_aclkr	pr1_pru0_pru_r30_4	pr1_pru0_pru_r31_4		gpio3[18]
43-46	GND									

7.2 Power Jack

The DC power jack is located next to the RJ45 Ethernet connector as shown in «figure-51». This uses the same power connector as is used on the original BeagleBone. The connector has a 2.1mm diameter center post (5VDC) and a 5.5mm diameter outer dimension on the barrel (GND).

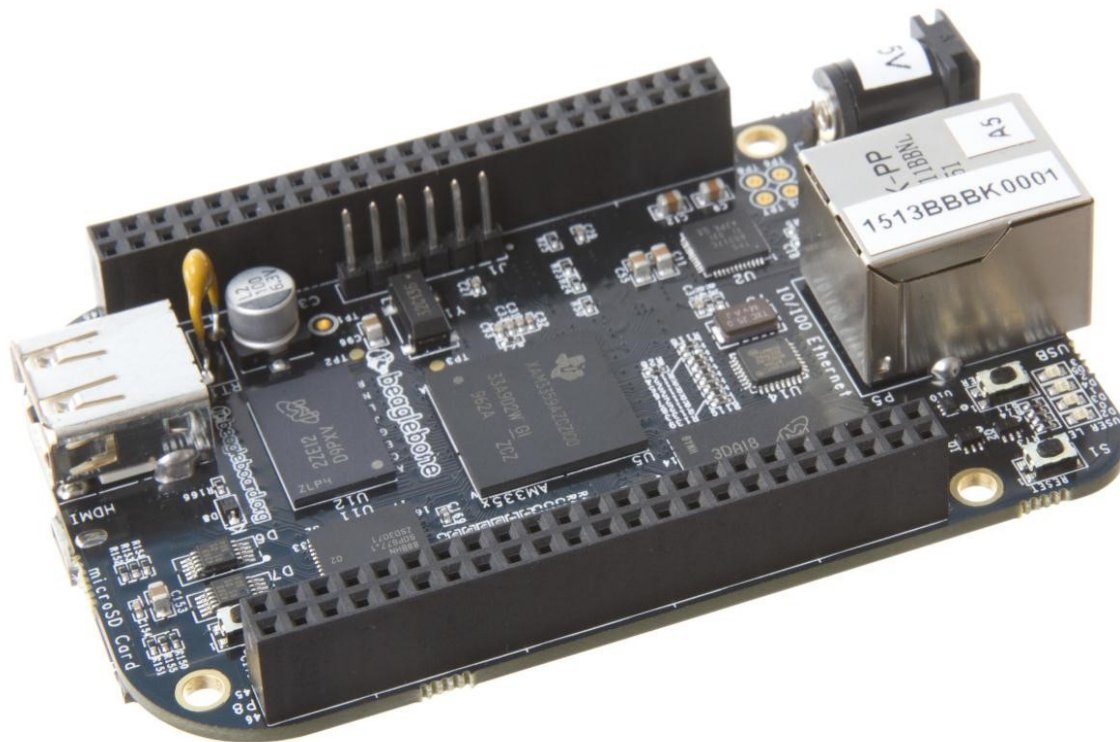

Fig. 7.2: 5VDC Power Jack

The board requires a regulated 5VDC +/- .25V supply at 1A. A higher current rating may be needed if capes are plugged into the expansion headers. Using a higher current power supply will not damage the board.

7.3 USB Client

The USB Client connector is accessible on the bottom side of the board under the row of four LEDs as shown in «figure-52». It uses a 5 pin miniUSB cable, the same as is used on the original BeagleBone. The cable is provided with the board. The cable can also be used to power the board.

This port is a USB Client only interface and is intended for connection to a PC.

7.4 USB Host

There is a single USB Host connector on the board and is shown in *Figure 53* below.

The port is USB 2.0 HS compatible and can supply up to 500mA of current. If more current or ports is needed, then a HUB can be used.

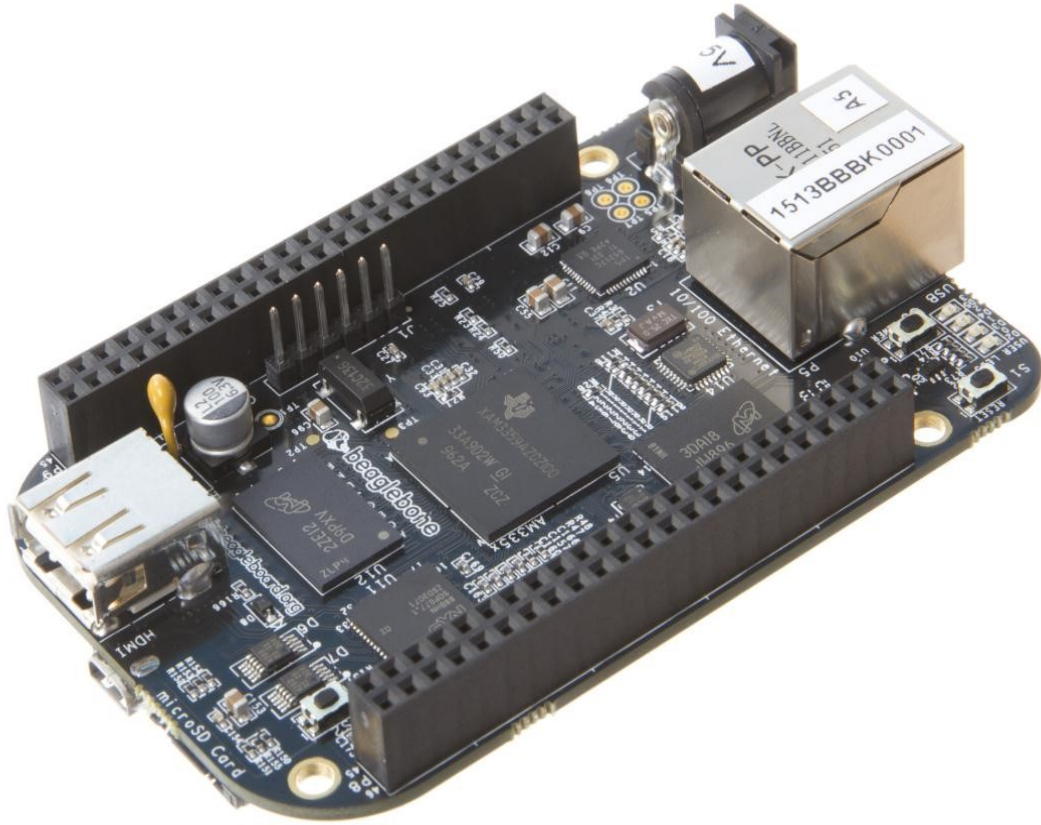

Fig. 7.3: USB Client

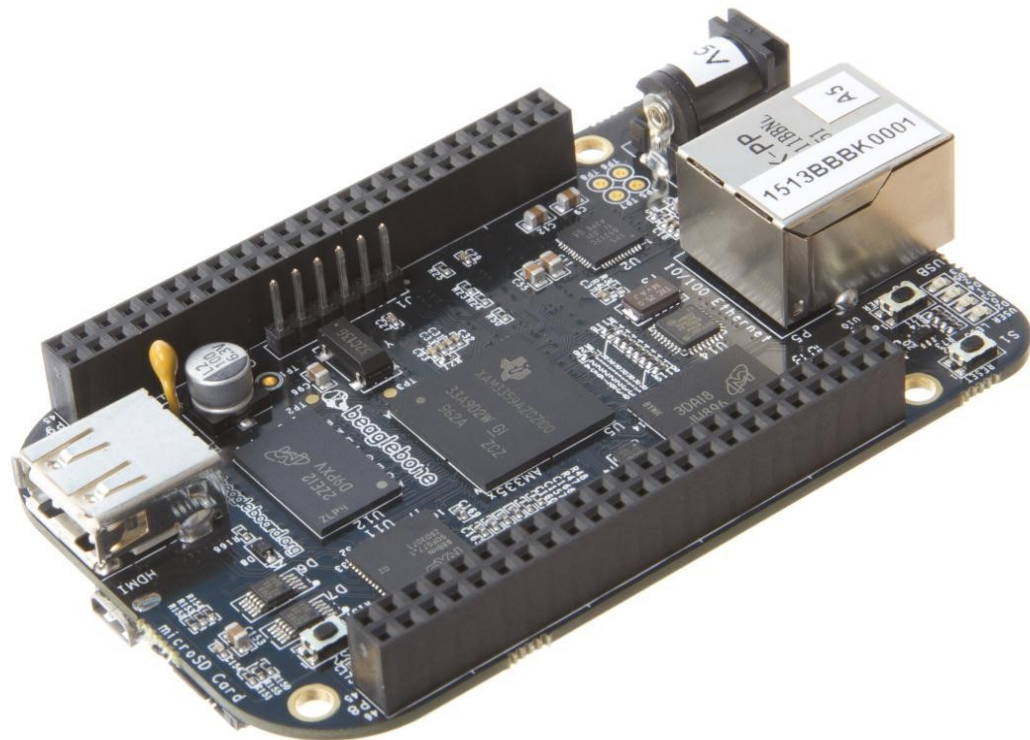

Fig. 7.4: USB Host Connector

7.5 Serial Header

Each board has a debug serial interface that can be accessed by using a special serial cable that is plugged into the serial header as shown in *Figure 54* below.

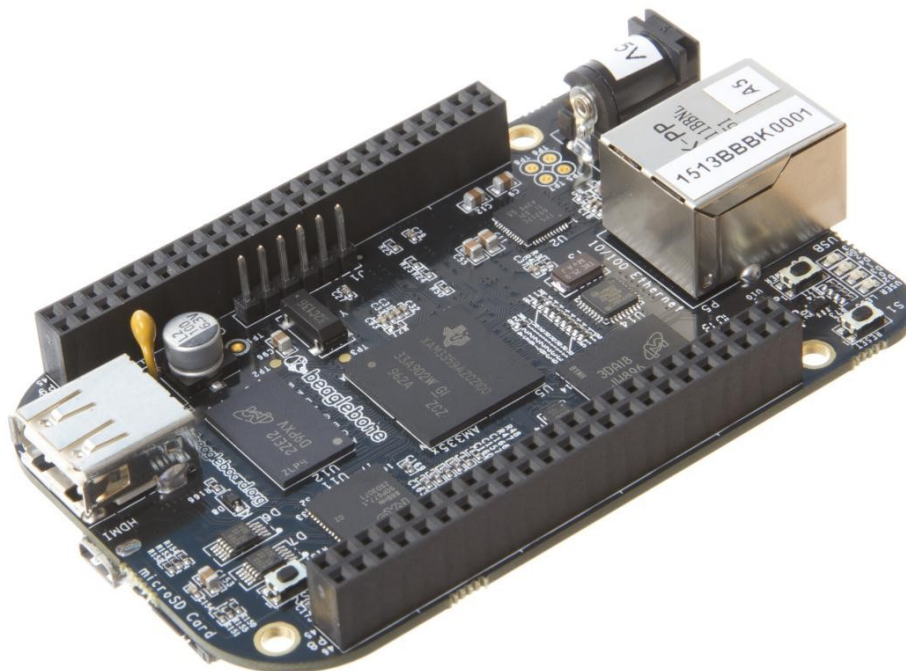

Fig. 7.5: Serial Debug Header

Two signals are provided, TX and RX on this connector. The levels on these signals are 3.3V. In order to access these signals, a FTDI USB to Serial cable is recommended as shown in *Figure 55* below.



Fig. 7.6: PRU-ICSS Block Diagram

The cable can be purchased from several different places and must be the 3.3V version TTL-232R-3V3. Information on the cable itself can be found direct from FTDI at: [pdf](#)

Pin 1 of the cable is the black wire. That must align with the pin 1 on the board which is designated by the white dot next to the connector on the board.

Refer to the support WIKI <http://elinux.org/BeagleBoneBlack> for more sources of this cable and other options that will work.

Table is the pinout of the connector as reflected in the schematic. It is the same as the FTDI cable which can be found at https://ftdichip.com/wp-content/uploads/2020/07/DS_USB_RS232_CABLES.pdf with the exception that only three pins are used on the board. The pin numbers are defined in *Table 14*. The signals are from the perspective of the board.

Table 7.3: J1 Serial Header Pins

PIN NUMBER	SIGNAL
1	Ground
4	Receive
5	Transmit



Fig. 7.7: Serial Header

7.6 HDMI

Access to the HDMI interface is through the HDMI connector that is located on the bottom side of the board as shown in *Figure 57* below.

The connector is microHDMI connector. This was done due to the space limitations we had in finding a place to fit the connector. It requires a microHDMI to HDMI cable as shown in *Figure 58* below. The cable can be purchased from several different sources.

7.7 microSD

A microSD connector is located on the back or bottom side of the board as shown in *Figure 59* below. The microSD card is not supplied with the board.

When plugging in the SD card, the writing on the card should be up. Align the card with the connector and push to insert. Then release. There should be a click and the card will start to eject slightly, but it then should latch into the connector. To eject the card, push the SD card in and then remove your finger. The SD card will be ejected from the connector.

Do not pull the SD card out or you could damage the connector.

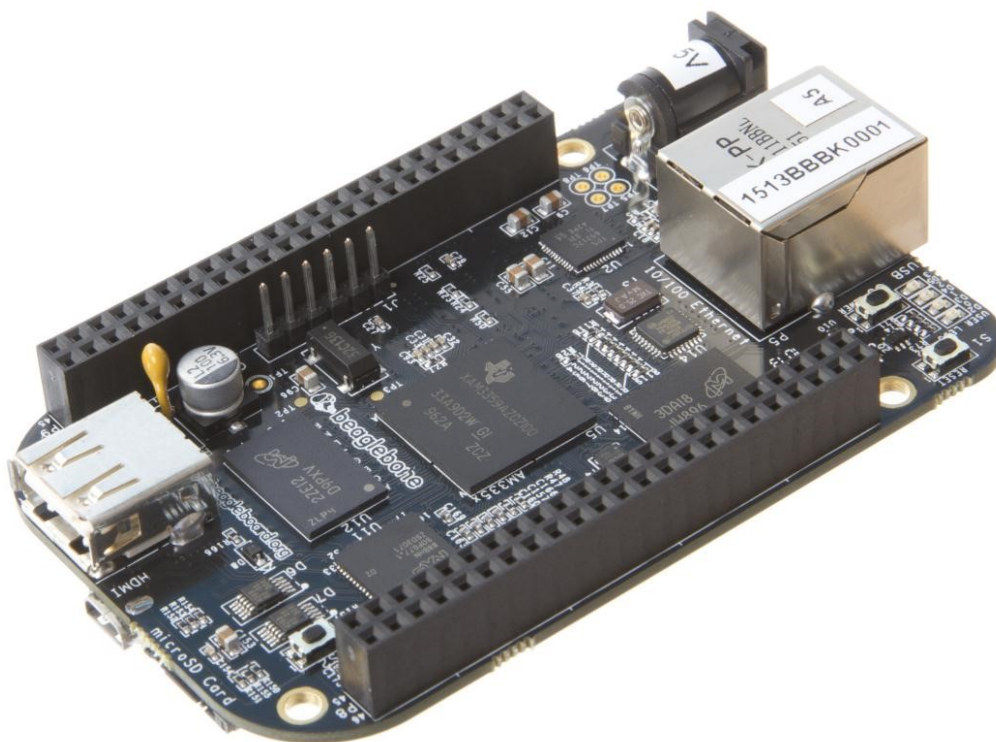

Fig. 7.8: HDMI Connector



Fig. 7.9: HDMI Cable

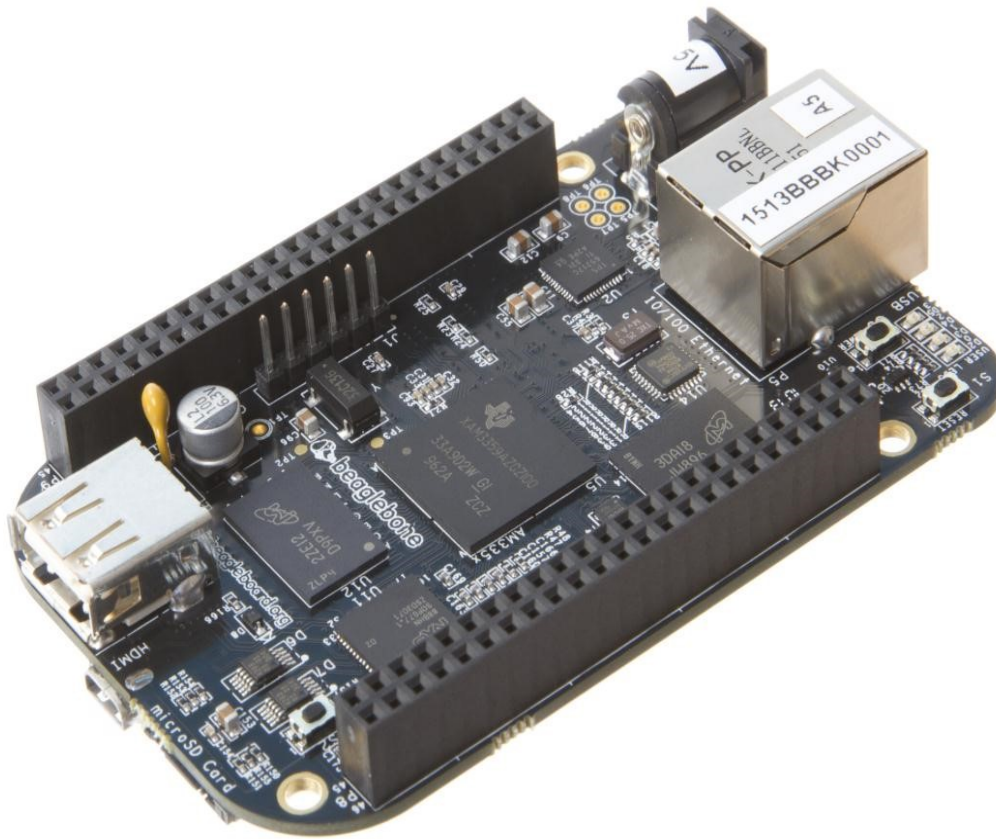

Fig. 7.10: microSD Connector

7.8 Ethernet

The board comes with a single 10/100 Ethernet interface located next to the power jack as shown in Figure below.

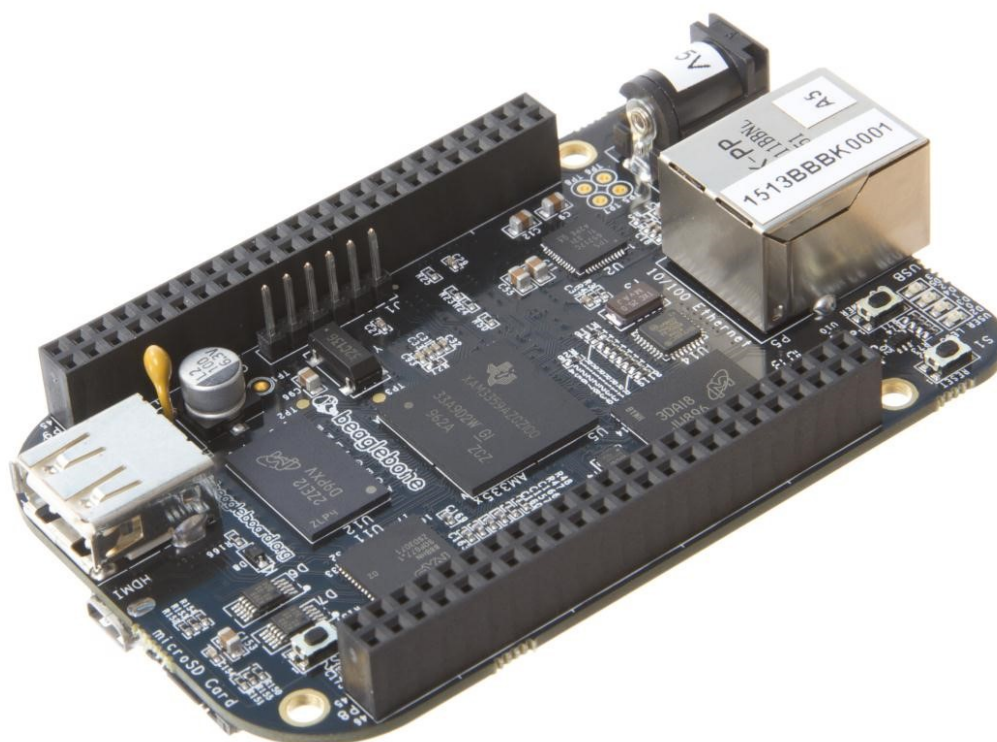

Fig. 7.11: Ethernet Connector

The PHY supports AutoMDX which means either a straight or a swap cable can be used.

7.9 JTAG Connector

A place for an optional 20 pin CTI JTAG header is provided on the board to facilitate the SW development and debugging of the board by using various JTAG emulators. This header is not supplied standard on the board. To use this, a connector will need to be soldered onto the board.

If you need the JTAG connector you can solder it on yourself. No other components are needed. The connector is made by Samtec and the part number is FTR-110-03-G-D-06. You can purchase it from <http://www.digikey.com/>

Chapter 8

Cape Board Support

The BeagleBone Black has the ability to accept up to four expansion boards or capes that can be stacked onto the expansion headers. The word cape comes from the shape of the board as it is fitted around the Ethernet connector on the main board. This notch acts as a key to ensure proper orientation of the cape.

This section describes the rules for creating capes to ensure proper operation with the BeagleBone Black and proper interoperability with other capes that are intended to coexist with each other. Co-existence is not a requirement and is in itself, something that is impossible to control or administer. But, people will be able to create capes that operate with other capes that are already available based on public information as it pertains to what pins and features each cape uses. This information will be able to be read from the EEPROM on each cape.

This section is intended as a guideline for those wanting to create their own capes. Its intent is not to put limits on the creation of capes and what they can do, but to set a few basic rules that will allow the SW to administer their operation with the BeagleBone Black. For this reason there is a lot of flexibility in the specification that we hope most people will find liberating and in the spirit of Open Source Hardware. I am sure there are others that would like to see tighter control, more details, more rules and much more order to the way capes are handled.

Over time, this specification will change and be updated, so please refer to the latest version of this manual prior to designing your own capes to get the latest information.

DO NOT APPLY VOLTAGE TO ANY I/O PIN WHEN

POWER IS NOT SUPPLIED TO THE BOARD. IT WILL DAMAGE THE PROCESSOR AND VOID THE WARRANTY.

NO PINS ARE TO BE DRIVEN UNTIL AFTER THE SYS_RESET LINE GOES HIGH.

8.1 BeagleBone Black Cape Compatibility

The main expansion headers are the same between the BeagleBone and BeagleBone Black. While the pins are the same, some of these pins are now used on the BeagleBone Black. The following sections discuss these pins.

The Power Expansion header was removed from the BeagleBone Black and is not available.

PAY VERY CLOSE ATTENTION TO THIS SECTION AND READ CAREFULLY!!

8.1.1 LCD Pins

The LCD pins are used on the BeagleBone Black to drive the HDMI framer. These signals are listed in *Table 15* below.

Table 8.1: P8 LCD Conflict Pins

PIN	PROC	NAME	MODE0
27	U5	GPIO2_22	lcd_vsync
28	V5	GPIO2_24	lcd_pclk
29	R5	GPIO2_23	lcd_hsync
30	R6	GPIO2_25	lcd_ac_bias_en
31	V4	UART5_CTSN	lcd_data14
32	T5	UART5_RTSN	lcd_data15
33	V3	UART4_RTSN	lcd_data13
34	U4	UART3_RTSN	lcd_data11
35	V2	UART4_CTSN	lcd_data12
36	U3	UART3_CTSN	lcd_data10
37	U1	UART5_TXD	lcd_data8
38	U2	UART5_RXD	lcd_data9
39	T3	GPIO2_12	lcd_data6
40	T4	GPIO2_13	lcd_data7
41	T1	GPIO2_10	lcd_data4
42	T2	GPIO2_11	lcd_data5
43	R3	GPIO2_8	lcd_data2
44	R4	GPIO2_9	lcd_data3
45	R1	GPIO2_6	lcd_data0
46	R2	GPIO2_7	lcd_data1

If you are using these pins for other functions, there are a few things to keep in mind:

- On the HDMI Framer, these signals are all inputs so the framer will not be driving these pins.
- The HDMI framer will add a load onto these pins.
- There are small filter caps on these signals which could also change the operation of these pins if used for other functions.
- When used for other functions, the HDMI framer cannot be used.
- There is no way to power off the framer as this would result in the framer being powered through these input pins which would not a be a good idea.
- These pins are also the *SYSBOOT* pins. DO NOT drive them before the **SYS_RESETN** signal goes high. If you do, the board may not boot because you would be changing the boot order of the processor.

In order to use these pins, the SW will need to reconfigure them to whatever function you need the pins to do. To keep power low, the HDMI framer should be put in a low power mode via the SW using the *I2C0* interface.

8.1.2 eMMC Pins

The BeagleBone Black uses 10 pins to connect to the processor that also connect to the P8 expansion connector. These signals are listed below in *Table 16*. The proper mode is MODE2.

Table 8.2: P8 eMMC Conflict Pins

PIN	PROC	SIGNAL	MODE
22	V8	MMC1_DAT5	1
23	U8	MMC1_DAT4	1
24	V7	MMC1_DAT1	1
5	R8	MMC1_DAT2	1
4	T9	MMC1_DAT7	1
3	R9	MMC1_DAT6	1
6	T8	MMC1_DAT3	1

continues on next page

Table 8.2 – continued from previous page

PIN	PROC	SIGNAL	MODE
25	U7	MMC1_DAT0	1
20	V9	MMC1_CMD	2
21	U9	MMC1_CLK	2

If using these pins, several things need to be kept in mind when doing so:

- On the eMMC device, these signals are inputs and outputs.
- The eMMC device will add a load onto these pins.
- When used for other functions, the eMMC cannot be used. This means you must boot from the microSD slot.
- If using these pins, you need to put the eMMC into reset. This requires that the eMMC be accessible from the processor in order to set the eMMC to accept the eMMC pins.
- DO NOT drive the eMMC pins until the eMMC has been put into reset. This means that if you choose to use these pins, they must not drive any signal until enabled via Software. This requires a buffer or some other form of hold off function enabled by a GPIO pin on the expansion header.

On power up, the eMMC is NOT reset. If you hold the Boot button down, this will force a boot from the microSD. This is not convenient when a cape is plugged into the board. There are two solutions to this issue:

1. Wipe the eMMC clean. This will cause the board to default to microSD boot. If you want to use the eMMC later, it can be reprogrammed. 2. You can also tie LCD_DATA2 low on the cape during boot. This will be the same as if you were holding the boot button. However, in order to prevent unforeseen issues, you need to gate this signal with RESET, when the data is sampled. After set goes high, the signal should be removed from the pin.

BEFORE the SW reinitializes the pins, it **MUST** put the eMMC in reset. This is done by taking eMMC_RSTn (GPIO1_20) LOW **after** the eMMC has been put into a mode to enable the reset line. This pin does not connect to the expansion header and is accessible only on the board.

DO NOT automatically drive any conflicting pins until the SW enables it. This puts the SW in control to ensure that the eMMC is in reset before the signals are used from the cape. You can use a GPIO pin for this. No, we will not designate a pin for this function. It will be determined on a cape by cape basis by the designer of the respective cape.

8.1.3 EEPROM

Each cape must have its own EEPROM containing information that will allow the SW to identify the board and to configure the expansion headers pins as needed. The one exception is proto boards intended for prototyping. They may or may not have an EEPROM on them. An EEPROM is required for all capes sold in order for them operate correctly when plugged into the BeagleBone Black.

The address of the EEPROM will be set via either jumpers or a dipswitch on each expansion board. *Figure 61* below is the design of the EEPROM circuit.

The EEPROM used is the same one as is used on the BeagleBone and the BeagleBone Black, a CAT24C256. The CAT24C256 is a 256 kb Serial CMOS EEPROM, internally organized as 32,768 words of 8 bits each. It features a 64-byte page write buffer and supports the Standard (100 kHz), Fast (400 kHz) and Fast-Plus (1 MHz) I2C protocol.

The addressing of this device requires two bytes for the address which is not used on smaller size EEPROMs, which only require only one byte. Other compatible devices may be used as well. Make sure the device you select supports 16 bit addressing. The part package used is at the discretion of the cape designer.

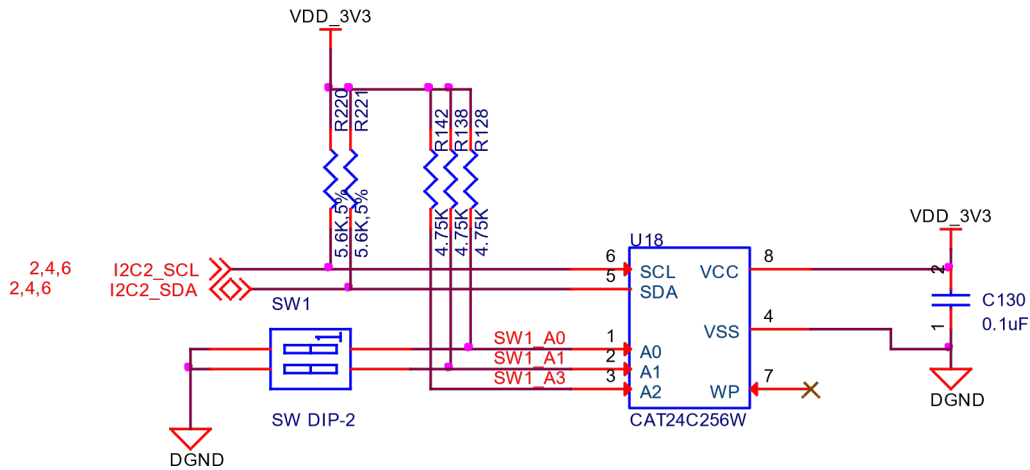

Fig. 8.1: Expansion Board EEPROM Without Write Protect

8.1.4 EEPROM Address

In order for each cape to have a unique address, a board ID scheme is used that sets the address to be different depending on the setting of the dipswitch or jumpers on the capes. A two position dipswitch or jumpers is used to set the address pins of the EEPROM.

It is the responsibility of the user to set the proper address for each board and the position in the stack that the board occupies has nothing to do with which board gets first choice on the usage of the expansion bus signals. The process for making that determination and resolving conflicts is left up to the SW and, as of this moment in time, this method is a something of a mystery due to the new Device Tree methodology introduced in the 3.8 kernel.

Address line A2 is always tied high. This sets the allowable address range for the expansion cards to 0x54 to 0x57. All other I2C addresses can be used by the user in the design of their capes. But, these addresses must not be used other than for the board EEPROM information. This also allows for the inclusion of EEPROM devices on the cape if needed without interfering with this EEPROM. It requires that A2 be grounded on the EEPROM not used for cape identification.

8.1.5 I2C Bus

The EEPROMs on each expansion board are connected to I2C2 on connector P9 pins 19 and 20. For this reason I2C2 must always be left connected and should not be changed by SW to remove it from the expansion header pin mux settings. If this is done, the system will be unable to detect the capes.

The I2C signals require pullup resistors. Each board must have a 5.6K resistor on these signals. With four capes installed this will result in an effective resistance of 1.4K if all capes were installed and all the resistors used were exactly 5.6K. As more capes are added the resistance is reduced to overcome capacitance added to the signals. When no capes are installed the internal pullup resistors must be activated inside the processor to prevent I2C timeouts on the I2C bus.

The I2C bus may also be used by capes for other functions such as I/O expansion or other I2C compatible devices that do not share the same address as the cape EEPROM.

EEPROM *****

The design in Figure 62 has the write protect disabled. If the write protect is not enabled, this does expose the EEPROM to being corrupted if the I2C bus is used on the cape and the wrong address written to. It is recommended that a write protection function be implemented and a Test Point be added that when grounded, will allow the EEPROM to be written to. To enable write operation, Pin 7 of the EEPROM must be tied to ground.

When not grounded, the pin is HI via pullup resistor R210 and therefore write protected. Whether or not Write Protect is provided is at the discretion of the cape designer.

Variable & MAC Memory VDD_3V3B

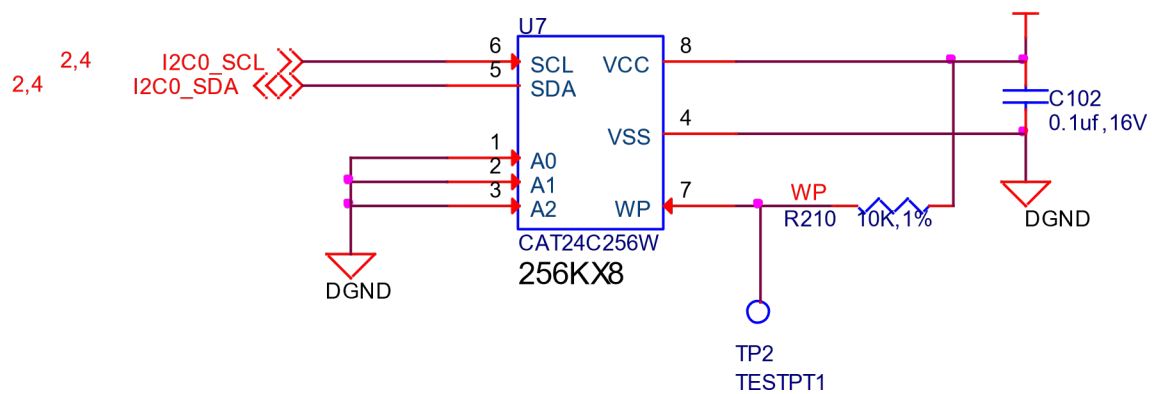

Fig. 8.2: Expansion Board EEPROM Write Protect

8.1.6 EEPROM Data Format

Table below shows the format of the contents of the expansion board EEPROM. Data is stored in Big Endian with the least significant value on the right. All addresses read as a single byte data from the EEPROM, but two byte addressing is used. ASCII values are intended to be easily read by the user when the EEPROM contents are dumped.

Name	Offset	Size (bytes)	Contents
Header	0	4	0xAA, 0x55, 0x33, 0xEE
EEPROM Revision	4	2	Revision number of the overall format of this EEPROM in ASCII =A1
Board Name	6	32	Name of board in ASCII so user can read it when the EEPROM is dumped. Up to
Version	38	4	Hardware version code for board in ASCII. Version format is up to the developer.
Manufacturer	42	16	ASCII name of the manufacturer. Company or individual's name.
Part Number	58	16	ASCII Characters for the part number. Up to maker of the board.
Number of Pins	74	2	Number of pins used by the daughter board including the power pins used. Dec
Serial Number	76	12	Serial number of the board. This is a 12 character string which is: WWYY&&&
Pin Usage	88	148	Two bytes for each configurable pins of the 74 pins on the expansion connector
VDD_3V3B Current	236	2	Maximum current in milliamps. This is HEX value of the current in decimal 1500
VDD_5V Current	238	2	Maximum current in milliamps. This is HEX value of the current in decimal 1500
SYS_5V Current	240	2	Maximum current in milliamps. This is HEX value of the current in decimal 1500
DC Supplied	242	2	Indicates whether or not the board is supplying voltage on the VDD_5V rail and
Available	244	32543	Available space for other non-volatile codes/data to be used as needed by the r

8.1.7 Pin Usage

Table 18 is the locations in the EEPROM to set the I/O pin usage for the cape. It contains the value to be written to the Pad Control Registers. Details on this can be found in section 9.2.2 of the *AM3358 Technical Reference Manual*. The table is left blank as a convenience and can be printed out and used as a template for creating a custom setting for each cape. The 16 bit integers and all 16 bit fields are to be stored in Big Endian format.

Bit 15 PIN USAGE is an indicator and should be a 1 if the pin is used or 0 if it is unused.

Bits 14-7 RESERVED is not to be used and left as 0.

Bit 6 SLEW CONTROL 0=Fast 1=Slow

Bit 5 RX Enabled 0=Disabled 1=Enabled

Bit 4 PU/PD 0=Pulldown 1=Pullup.

Bit 3 PULLUP/DN 0=Pullup/pulldown enabled 1= Pullup/pulldown disabled

Bit 2-0 MUX MODE SELECT Mode 0-7. (refer to TRM)

Refer to the TRM for proper settings of the pin MUX mode based on the signal selection to be used.

The *AIN0-6* pins do not have a pin mux setting, but they need to be set to indicate if each of the pins is used on the cape. Only bit 15 is used for the AIN signals.

Table 8.4: EEPROM Pin Usage

Off set	Conn	Name	Pin Usage	Type	13	12	11	10	9	8	7	6	5
88	P9-22	UART2_RXD	+	+	+	+	+	+	+	+	+	+	+
90	P9-21	UART2_TXD	+	+	+	+	+	+	+	+	+	+	+
92	P9-18	I2C1_SDA	+	+	+	+	+	+	+	+	+	+	+
94	P9-17	I2C1_SCL	+	+	+	+	+	+	+	+	+	+	+
96	P9-42	GPIO0_7	+	+	+	+	+	+	+	+	+	+	+
98	P8-35	UART4_CTSN	+	+	+	+	+	+	+	+	+	+	+
100	P8-33	UART4_RTSN	+	+	+	+	+	+	+	+	+	+	+
102	P8-31	UART5_CTSN	+	+	+	+	+	+	+	+	+	+	+
104	P8-32	UART5_RTSN	+	+	+	+	+	+	+	+	+	+	+
106	P9-19	I2C2_SCL	+	+	+	+	+	+	+	+	+	+	+
108	P9-20	I2C2_SDA	+	+	+	+	+	+	+	+	+	+	+
110	P9-26	UART1_RXD	+	+	+	+	+	+	+	+	+	+	+
112	P9-24	UART1_TXD	+	+	+	+	+	+	+	+	+	+	+
114	P9-41	CLKOUT2	+	+	+	+	+	+	+	+	+	+	+
116	P8-19	EHRPWM2A	+	+	+	+	+	+	+	+	+	+	+
118	P8-13	EHRPWM2B	+	+	+	+	+	+	+	+	+	+	+
120	P8-14	GPIO0_26	+	+	+	+	+	+	+	+	+	+	+
122	P8-17	GPIO0_27	+	+	+	+	+	+	+	+	+	+	+
124	P9-11	UART4_RXD	+	+	+	+	+	+	+	+	+	+	+
126	P9-13	UART4_TXD	+	+	+	+	+	+	+	+	+	+	+
128	P8-25	GPIO1_0	+	+	+	+	+	+	+	+	+	+	+
130	P8-24	GPIO1_1	+	+	+	+	+	+	+	+	+	+	+
132	P8-5	GPIO1_2	+	+	+	+	+	+	+	+	+	+	+
134	P8-6	GPIO1_3	+	+	+	+	+	+	+	+	+	+	+
136	P8-23	GPIO1_4	+	+	+	+	+	+	+	+	+	+	+
138	P8-22	GPIO1_5	+	+	+	+	+	+	+	+	+	+	+
140	P8-3	GPIO1_6	+	+	+	+	+	+	+	+	+	+	+
142	P8-4	GPIO1_7	+	+	+	+	+	+	+	+	+	+	+
144	P8-12	GPIO1_12	+	+	+	+	+	+	+	+	+	+	+
146	P8-11	GPIO1_13	+	+	+	+	+	+	+	+	+	+	+
148	P8-16	GPIO1_14	+	+	+	+	+	+	+	+	+	+	+
150	P8-15	GPIO1_15	+	+	+	+	+	+	+	+	+	+	+
152	P9-15	GPIO1_16	+	+	+	+	+	+	+	+	+	+	+

Off set	Conn	Name	Pin Usage	Type	14	13	12	11	10	9	8	7	6	5
					+	+	Reserve	+	+	SLEW	RX	P.U.-P.D	P.U./DEN	Mux Mode
154	P9-23	GPIO1_17												
156	P9-14	EHRPWM1A												
158	P9-16	EHRPWM1B												
160	P9-12	GPIO1_28												
162	P8-26	GPIO1_29												
164	P8-21	GPIO1_30												
166	P8-20	GPIO1_31												
168	P8-18	GPIO2_1												
170	P8-7	TIMER4												
172	P8-9	TIMER5												
174	P8-10	TIMER6												
176	P8-8	TIMER7												
178	P8-45	GPIO2_6												
180	P8-46	GPIO2_7												
182	P8-43	GPIO2_8												
184	P8-44	GPIO2_9												
186	P8-41	GPIO2_10												
188	P8-42	GPIO2_11												
190	P8-39	GPIO2_12												
192	P8-40	GPIO2_13												
194	P8-37	UART5_TX'+'												
196	P8-38	UART5_RX'+'												
198	P8-36	UART3_CTSN												
200	P8-34	UART3_RTSN												
202	P8-27	GPIO2_22												
204	P8-29	GPIO2_23												
206	P8-28	GPIO2_24												
208	P8-30	GPIO2_25												
210	P9-29	SPI1_D0												
212	P9-30	SPI1_D1												
214	P9-28	SPI1_CS0												
216	P9-27	GPIO3_19												
218	P9-31	SPI1_SCLK												
220	P9-25	GPIO3_21												
+			15	14	13	12	11	10	9	8	7	6	5	
+			Pin Usage	Type	Reserve	Reserve	Reserve	+	+	SLEW	RX	P.U.-P.D	P.U./DEN	Mux Mode
222	P9-39	AIN0	+	0	0	0	0	0	0	0	0	0	0	0
224	P9-40	AIN1	+	+	+	+	+	+	+	+	+	+	+	+
226	P9-37	AIN2	+	+	+	+	+	+	+	+	+	+	+	+
228	P9-38	AIN3	+	+	+	+	+	+	+	+	+	+	+	+
230	P9-33	AIN4	+	+	+	+	+	+	+	+	+	+	+	+
232	P9-36	AIN5	+	+	+	+	+	+	+	+	+	+	+	+
234	P9-35	AIN6	+	+	+	+	+	+	+	+	+	+	+	+

8.2 Pin Usage Consideration

This section covers things to watch for when hooking up to certain pins on the expansion headers.

8.2.1 Boot PIN

There are 16 pins that control the boot mode of the processor that are exposed on the expansion headers. Figure 63 below shows those signals as they appear on the BeagleBone Black.:

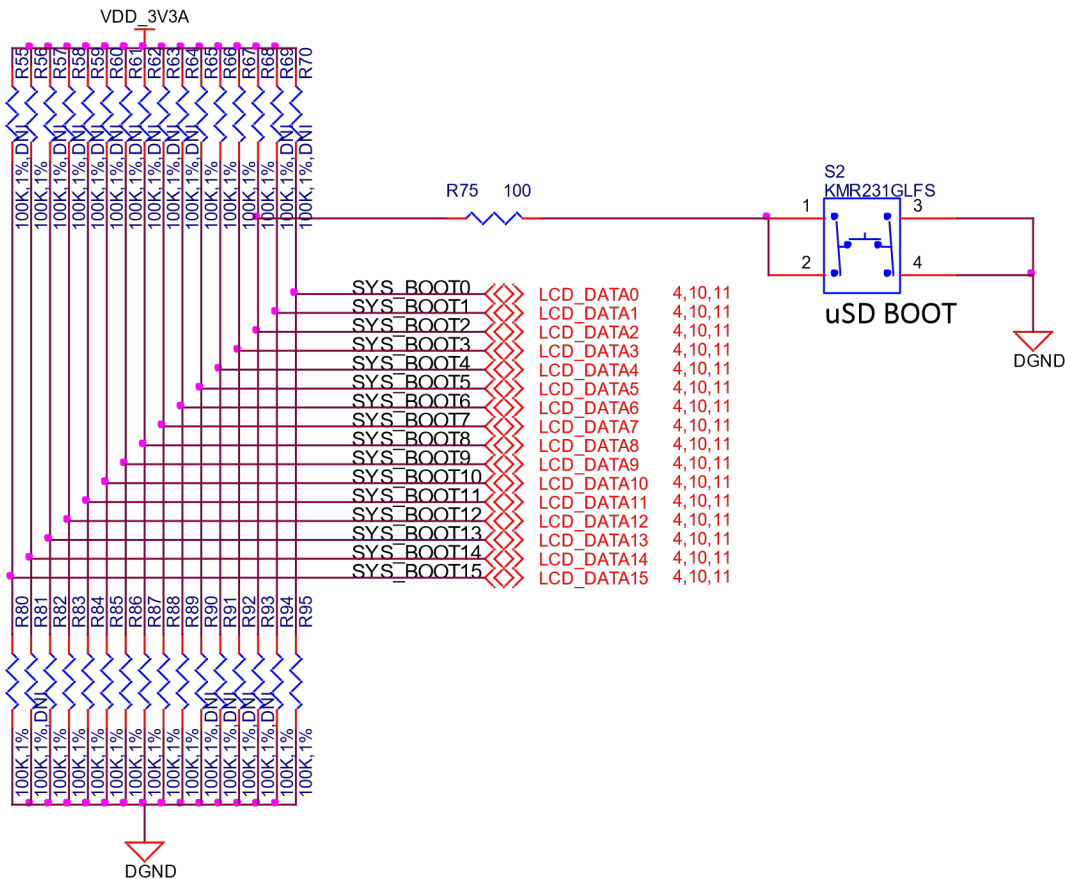

Figure 63. Expansion Boot Pins

Fig. 8.3: Boot signals

If you plan to use any of these signals, then on power up, these pins should not be driven. If you do, it can affect the boot mode of the processor and could keep the processor from booting or working correctly.

If you are designing a cape that is intended to be used as a boot source, such as a NAND board, then you should drive the pins to reconfigure the boot mode, but only at reset. After the reset phase, the signals should not be driven to allow them to be used for the other functions found on those pins. You will need to override the resistor values in order to change the settings. The DC pull-up requirement should be based on the AM3358 Vih min voltage of 2 volts and AM3358 maximum input leakage current of 18uA. Also take into account any other current leakage paths on these signals which could be caused by your specific cape design.

The DC pull-down requirement should be based on the AM3358 Vil max voltage of 0.8 volts and AM3358 maximum input leakage current of 18uA plus any other current leakage paths on these signals.

8.2.2 Expansion Connectors

A combination of male and female headers is used for access to the expansion headers on the main board. There are three possible mounting configurations for the expansion headers:

- *Single* no board stacking but can be used on the top of the stack.
- *Stacking-up* to four boards can be stacked on top of each other.
- *Stacking with signal stealing-up* to three boards can be stacked on top of each other, but certain boards will not pass on the signals they are using to prevent signal loading or use by other cards in the stack.

The following sections describe how the connectors are to be implemented and used for each of the different configurations.

8.2.3 Non-Stacking Headers-Single Cape

For non-stacking capes single configurations or where the cape can be the last board on the stack, the two 46 pin expansion headers use the same connectors. *Figure 64* is a picture of the connector. These are dual row 23 position 2.54mm x 2.54mm connectors.



Fig. 8.4: Single Expansion Connector

The connector is typically mounted on the bottom side of the board as shown in *Figure 65*. These are very common connectors and should be easily located. You can also use two single row 23 pin headers for each of the dual row headers.



Fig. 8.5: Single Cape Expansion Connector

It is allowed to only populate the pins you need. As this is a non-stacking configuration, there is no need for all headers to be populated. This can also reduce the overall cost of the cape. This decision is up to the cape designer.

For convenience listed in *Table 19* are some possible choices for part numbers on this connector. They have varying pin lengths and some may be more suitable than others for your use. It should be noted, that the longer the pin and the further it is inserted into the BeagleBone Black connector, the harder it will be to remove due to the tension on 92 pins. This can be minimized by using shorter pins or removing those pins that are not used by your particular design. The first item in *Table 18* is on the edge and may not be the best solution. Overhang is the amount of the pin that goes past the contact point of the connector on the BeagleBone Black

Table 8.6: Single Cape Connectors

SUPPLIER	PARTNUMBER	LENGTH(in)	OVERHANG(in)
Major League	TSHC-123-D-03-145-G-LF	.145	.004
Major League	TSHC-123-D-03-240-G-LF	.240	.099
Major League	TSHC-123-D-03-255-G-LF	.255	.114

The G in the part number is a plating option. Other options may be used as well as long as the contact area is gold. Other possible sources are Sullins and Samtec for these connectors. You will need to ensure the depth into the connector is sufficient

8.2.4 Main Expansion Headers-Stacking

For stacking configuration, the two 46 pin expansion headers use the same connectors. *Figure 66* is a picture of the connector. These are dual row 23 position 2.54mm x 2.54mm connectors.

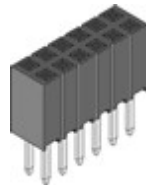

Fig. 8.6: Expansion Connector

The connector is mounted on the top side of the board with longer tails to allow insertion into the BeagleBone Black. *Figure 67* is the connector configuration for the connector.



Fig. 8.7: Stacked Cape Expansion Connector

For convenience listed in *Table 18* are some possible choices for part numbers on this connector. They have varying pin lengths and some may be more suitable than others for your use. It should be noted, that the longer the pin and the further it is inserted into the BeagleBone Black connector, the harder it will be to remove due to the tension on 92 pins. This can be minimized by using shorter pins. There are most likely other suppliers out there that will work for this connector as well. If anyone finds other suppliers of compatible connectors that work, let us know and they will be added to this document. The first item in *Table 19* is on the edge and may not be the best solution. Overhang is the amount of the pin that goes past the contact point of the connector on the BeagleBone Black.

The third part listed in *Table 20* will have insertion force issues.

Table 8.7: Stacked Cape Connectors

SUPPLIER	PARTNUMBER	TAIL LENGTH(in)	OVERHANG(in)
Major League	SSHQ-123-D-06-G-LF	.190	0.049
Major League	SSHQ-123-D-08-G-LF	.390	0.249
Major League	SSHQ-123-D-10-G-LF	.560	0.419

There are also different plating options on each of the connectors above. Gold plating on the contacts is the minimum requirement. If you choose to use a different part number for plating or availability purposes, make sure you do not select the "LT" option.

Other possible sources are Sullins and Samtec but make sure you select one that has the correct mating depth.

8.2.5 StackedStealing

Figure 68 is the connector configuration for stackable capes that does not provide all of the signals upwards for use by other boards. This is useful if there is an expectation that other boards could interfere with the

operation of your board by exposing those signals for expansion. This configuration consists of a combination of the stacking and nonstacking style connectors.

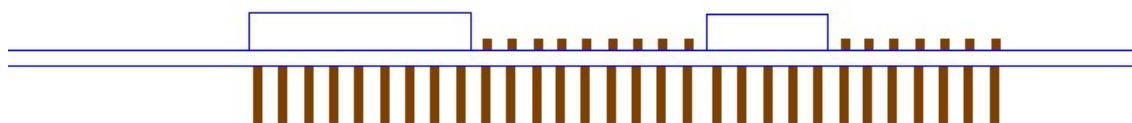

Fig. 8.8: Stacked w/Signal Stealing Expansion Connector

8.2.6 Retention Force

The length of the pins on the expansion header has a direct relationship to the amount of force that is used to remove a cape from the BeagleBone Black. The longer the pins extend into the connector the harder it is to remove. There is no rule that says that if longer pins are used, that the connector pins have to extend all the way into the mating connector on the BeagleBone Black, but this is controlled by the user and therefore is hard to control. We have also found that if you use gold pins, while more expensive, it makes for a smoother finish which reduces the friction.

This section will attempt to describe the tradeoffs and things to consider when selecting a connector and its pin length.

Figure 69 shows the key measurements used in calculating how much the pin extends past the contact point on the connector, what we call overhang.

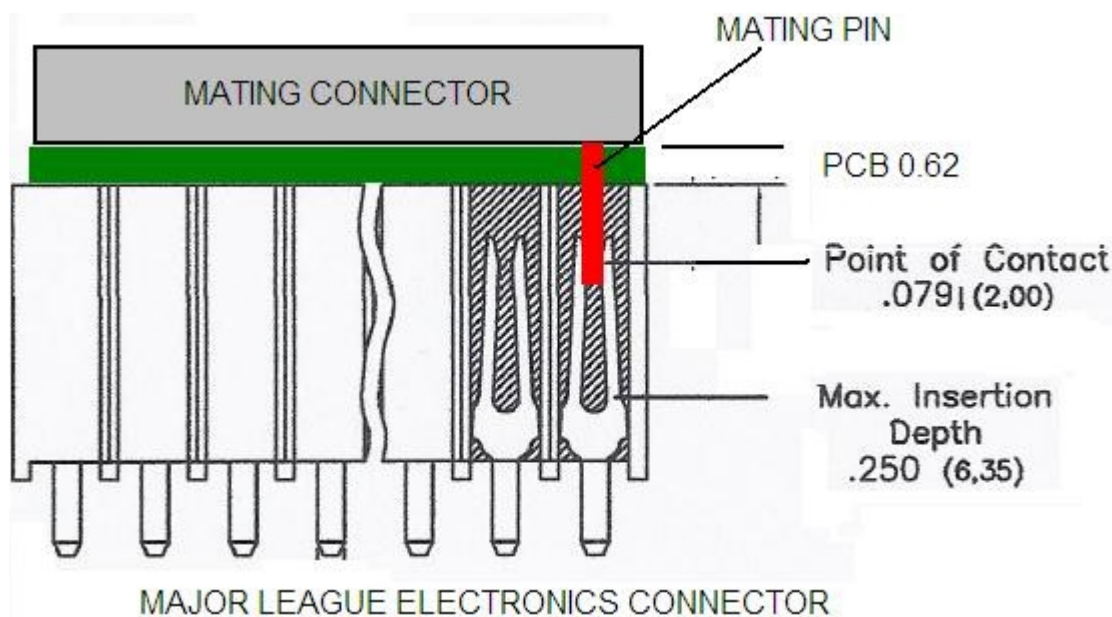

Fig. 8.9: Connector Pin Insertion Depth

To calculate the amount of the pin that extends past the Point of Contact, use the following formula:

$$\text{Overhang} = \text{Total Pin Length} - \text{PCB thickness (.062)} - \text{contact point (.079)}$$

The longer the pin extends past the contact point, the more force it will take to insert and remove the board. Removal is a greater issue than the insertion.

8.3 Signal Usage

Based on the pin muxing capabilities of the processor, each expansion pin can be configured for different functions. When in the stacking mode, it will be up to the user to ensure that any conflicts are resolved between multiple stacked cards. When stacked, the first card detected will be used to set the pin muxing of each pin. This will prevent other modes from being supported on stacked cards and may result in them being inoperative.

In «section-7-1» of this document, the functions of the pins are defined as well as the pin muxing options. Refer to this section for more information on what each pin is. To simplify things, if you use the default name as the function for each pin and use those functions, it will simplify board design and reduce conflicts with other boards.

Interoperability is up to the board suppliers and the user. This specification does not specify a fixed function on any pin and any pin can be used to the full extent of the functionality of that pin as enabled by the processor.

DO NOT APPLY VOLTAGE TO ANY I/O PIN WHEN POWER IS NOT SUPPLIED TO THE BOARD. IT WILL DAMAGE THE PROCESSOR AND VOID THE WARRANTY.

NO PINS ARE TO BE DRIVEN UNTIL AFTER THE SYS_RESET LINE GOES HIGH.

8.4 Cape Power

This section describes the power rails for the capes and their usage.

8.4.1 Main Board Power

The *Table 1* describes the voltages from the main board that are available on the expansion connectors and their ratings. All voltages are supplied by connector**P9**. The current ratings listed are per pin.

Table 8.8: Expansion Voltages

Current	Name	P9	P9	Name	Current
250mA	VDD_3V3B	3	4	VDD_3V3B	250mA
1000mA	VDD_5V	5	6	VDD_5V	1000mA
250mA	SYS_5V	7	8	SYS_5V	250mA

The *VDD_3V3B* rail is supplied by the LDO on the BeagleBone Black and is the primary power rail for expansion boards. If the power requirement for the capes exceeds the current rating, then locally generated voltage rail can be used. It is recommended that this rail be used to power any buffers or level translators that may be used.

VDD_5V is the main power supply from the DC input jack. This voltage is not present when the board is powered via USB. The amount of current supplied by this rail is dependent upon the amount of current available. Based on the board design, this rail is limited to 1A per pin from the main board.

The *SYS_5V* rail is the main rail for the regulators on the main board. When powered from a DC supply or USB, this rail will be 5V. The available current from this rail depends on the current available from the USB and DC external supplies.

8.4.2 Power

A cape can have a jack or terminals to bring in whatever voltages may be needed by that board. Care should be taken not to let this voltage be fed back into any of the expansion header pins.

It is possible to provide 5V to the main board from an expansion board. By supplying a 5V signal into the *VDD_5V* rail, the main board can be supplied. This voltage must not exceed 5V. You should not supply any

voltage into any other pin of the expansion connectors. Based on the board design, this rail is limited to 1A per pin to the BeagleBone Black.

There are several precautions that need to be taken when working with the expansion headers to prevent damage to the board.

1. Do not apply any voltages to any I/O pins when the board is not powered on.
2. Do not drive any external signals into the I/O pins until after the VDD_3V3B rail is up.
3. Do not apply any voltages that are generated from external sources.
4. If voltages are generated from the VDD_5V signal, those supplies must not become active until after the VDD_3V3B rail is up.
5. If you are applying signals from other boards into the expansion headers, make sure you power the board up after you power up the BeagleBone Black or make the connections after power is applied on both boards.

Powering the processor via its I/O pins can cause damage to the processor.

8.5 Mechanical

This section provides the guidelines for the creation of expansion boards from a mechanical standpoint. Defined is a standard board size that is the same profile as the BeagleBone Black. It is expected that the majority of expansion boards created will be of standard size. It is possible to create boards of other sizes and in some cases this is required, as in the case of an LCD larger than the BeagleBone Black board.

8.5.1 Standard Cape Size

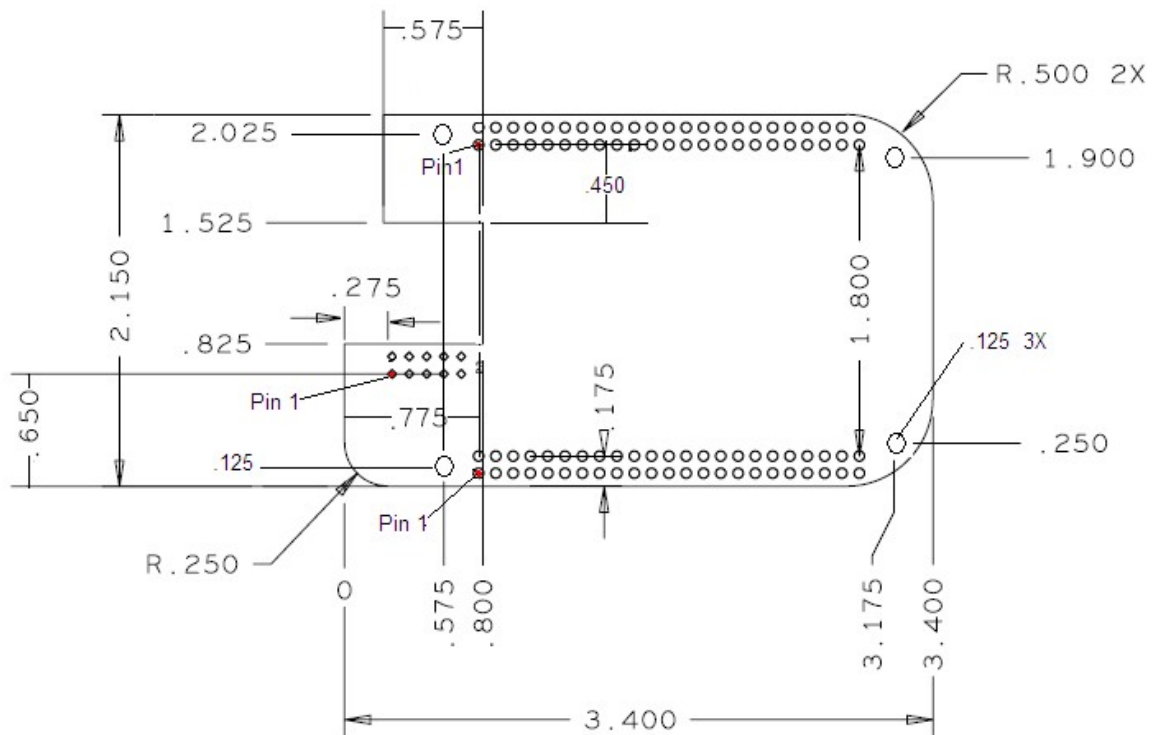

Fig. 8.10: Cape Board Dimensions

A slot is provided for the Ethernet connector to stick up higher than the cape when mounted. This also acts as a key function to ensure that the cape is oriented correctly. Space is also provided to allow access to the user LEDs and reset button on the main board.

Some people have inquired as to the difference in the radius of the corners of the BeagleBone Black and why they are different. This is a result of having the BeagleBone fit into the Altoids style tin.

It is not required that the cape be exactly like the BeagleBone Black board in this respect.

8.5.2 Extended Cape Size

Capes larger than the standard board size are also allowed. A good example would be an LCD panel. There is no practical limit to the sizes of these types of boards. The notch for the key is also not required, but it is up to the supplier of these boards to ensure that the BeagleBone Black is not plugged in incorrectly in such a manner that damage would be caused to the BeagleBone Black or any other capes that may be installed. Any such damage will be the responsibility of the supplier of such a cape to repair.

As with all capes, the EEPROM is required and compliance with the power requirements must be adhered to.

8.5.3 Enclosures

There are numerous enclosures being created in all different sizes and styles. The mechanical design of these enclosures is not being defined by this specification.

The ability of these designs to handle all shapes and sizes of capes, especially when you consider up to four can be mounted with all sorts of interface connectors, it is difficult to define a standard enclosure that will handle all capes already made and those yet to be defined.

If cape designers want to work together and align with one enclosure and work around it that is certainly acceptable. But we will not pick winners and we will not do anything that impedes the openness of the platform and the ability of enclosure designers and cape designers to innovate and create new concepts.

Chapter 9

BeagleBone Black Mechanical

9.1 Dimensions and Weight

Size: 3.5" x 2.15" (86.36mm x 53.34mm)

Max height: .187" (4.76mm)

PCB Layers: 6

PCB thickness: .062"

RoHS Compliant: Yes

Weight: 1.4 oz

9.2 Silkscreen and Component Locations

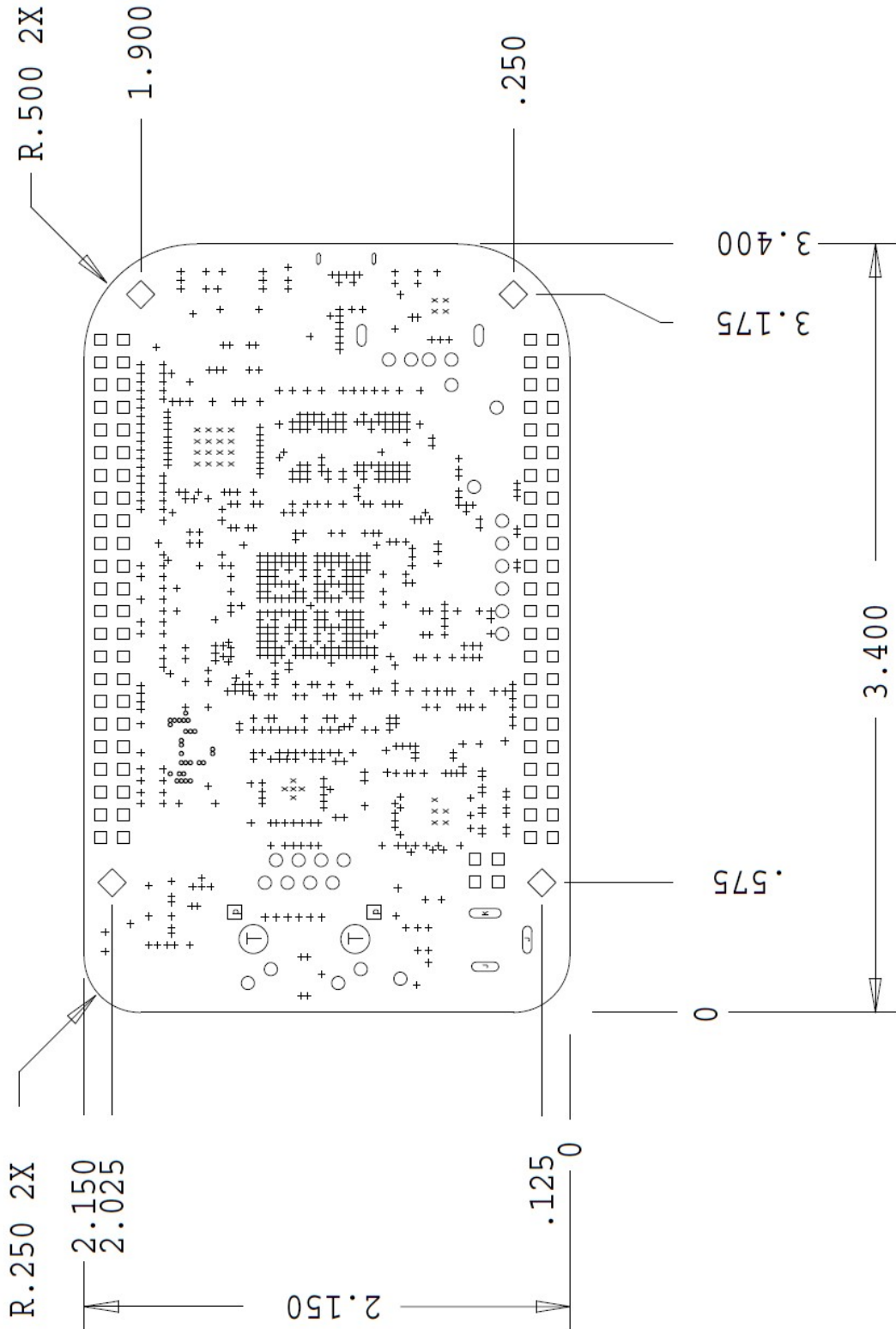

Fig. 9.1: Board Dimensions

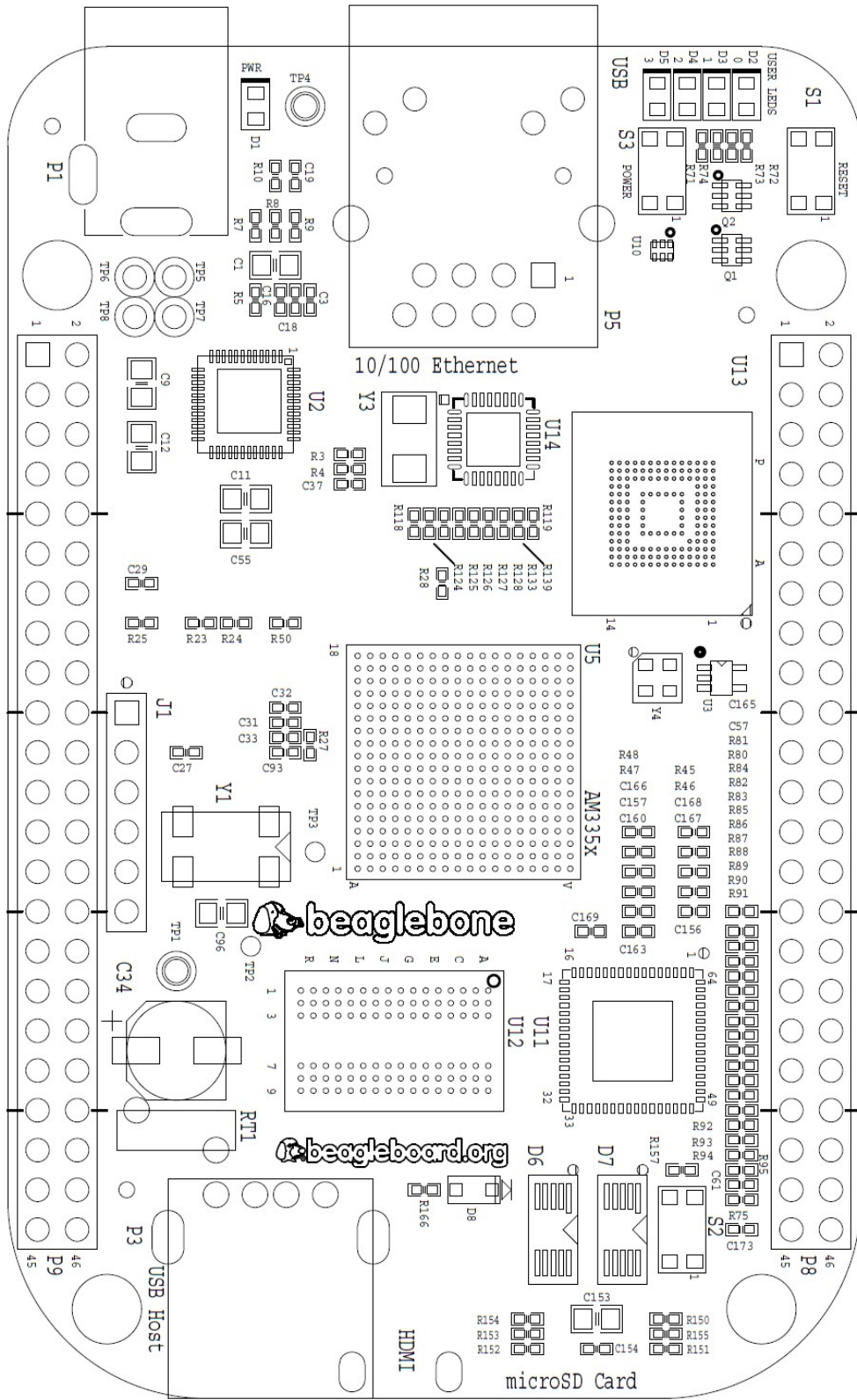

Fig. 9.2: Component Side Silkscreen

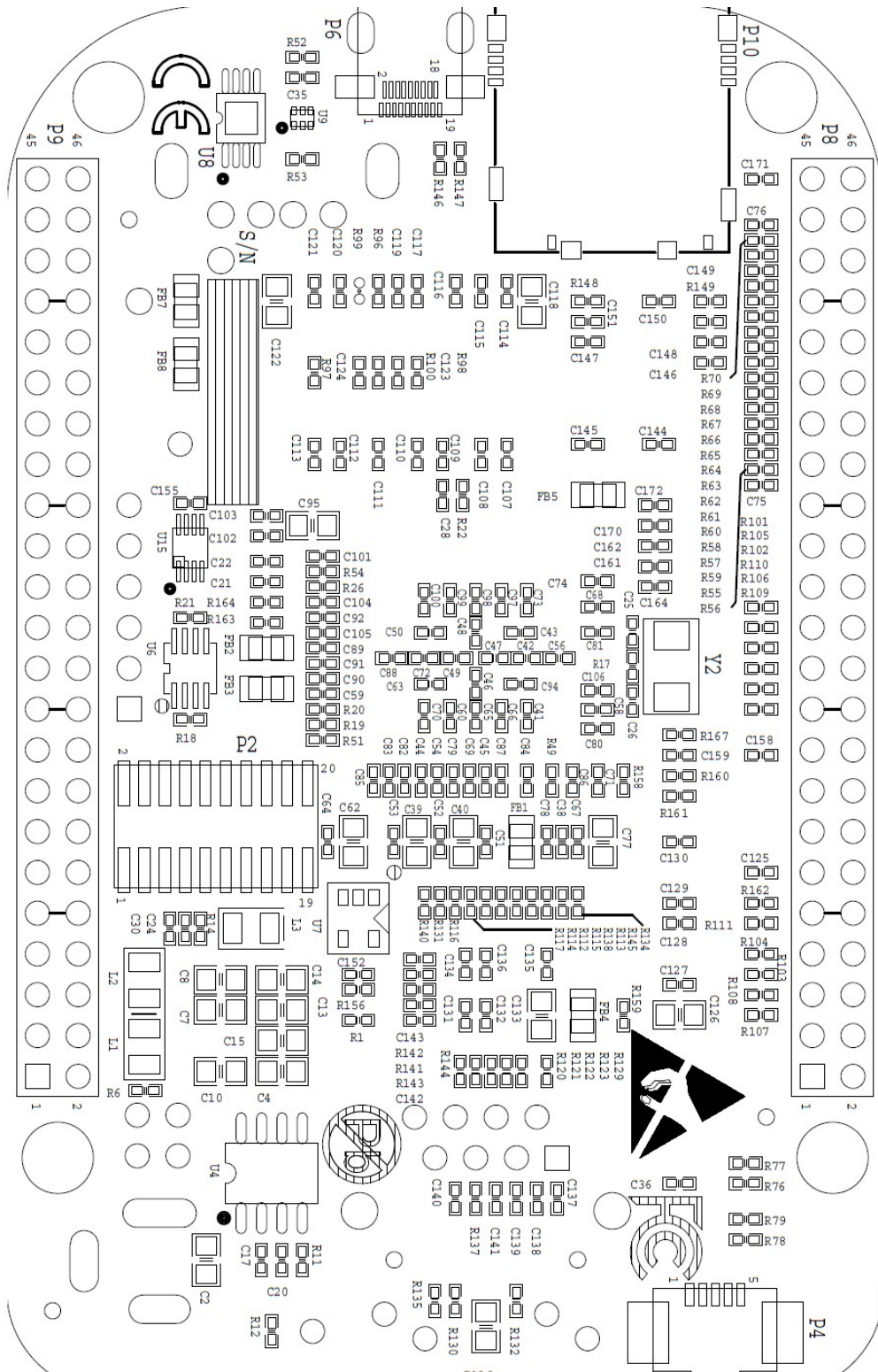

Fig. 9.3: Circuit Side Silkscreen

Chapter 10

Pictures

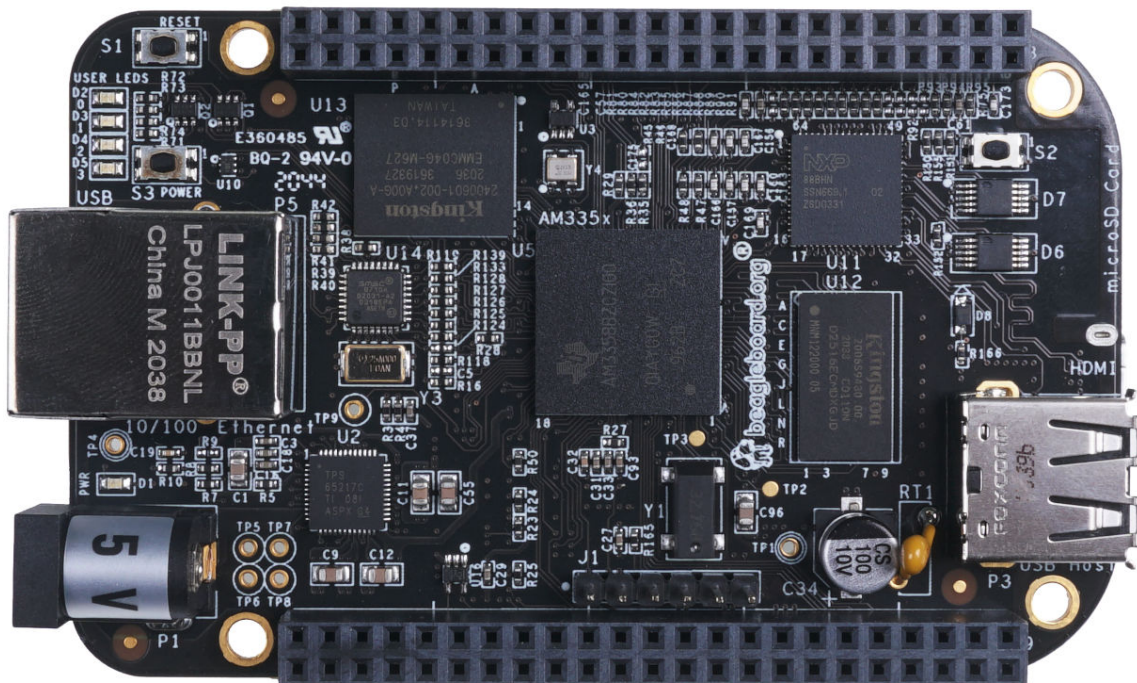

Fig. 10.1: Top Side

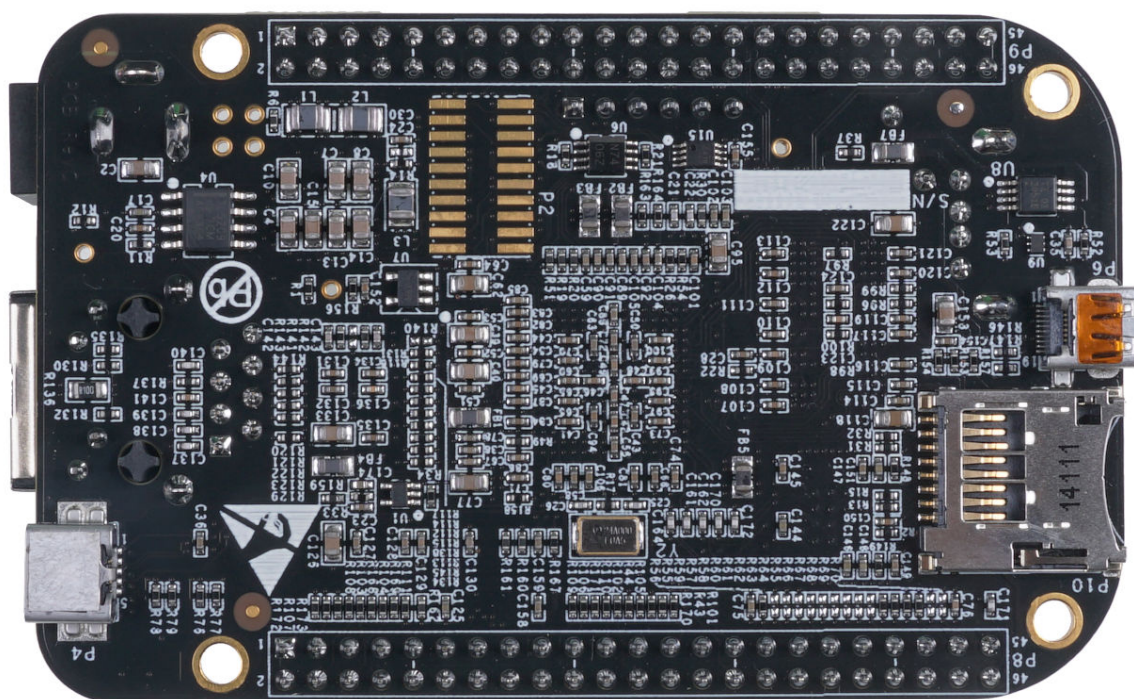

Fig. 10.2: Bottom Side

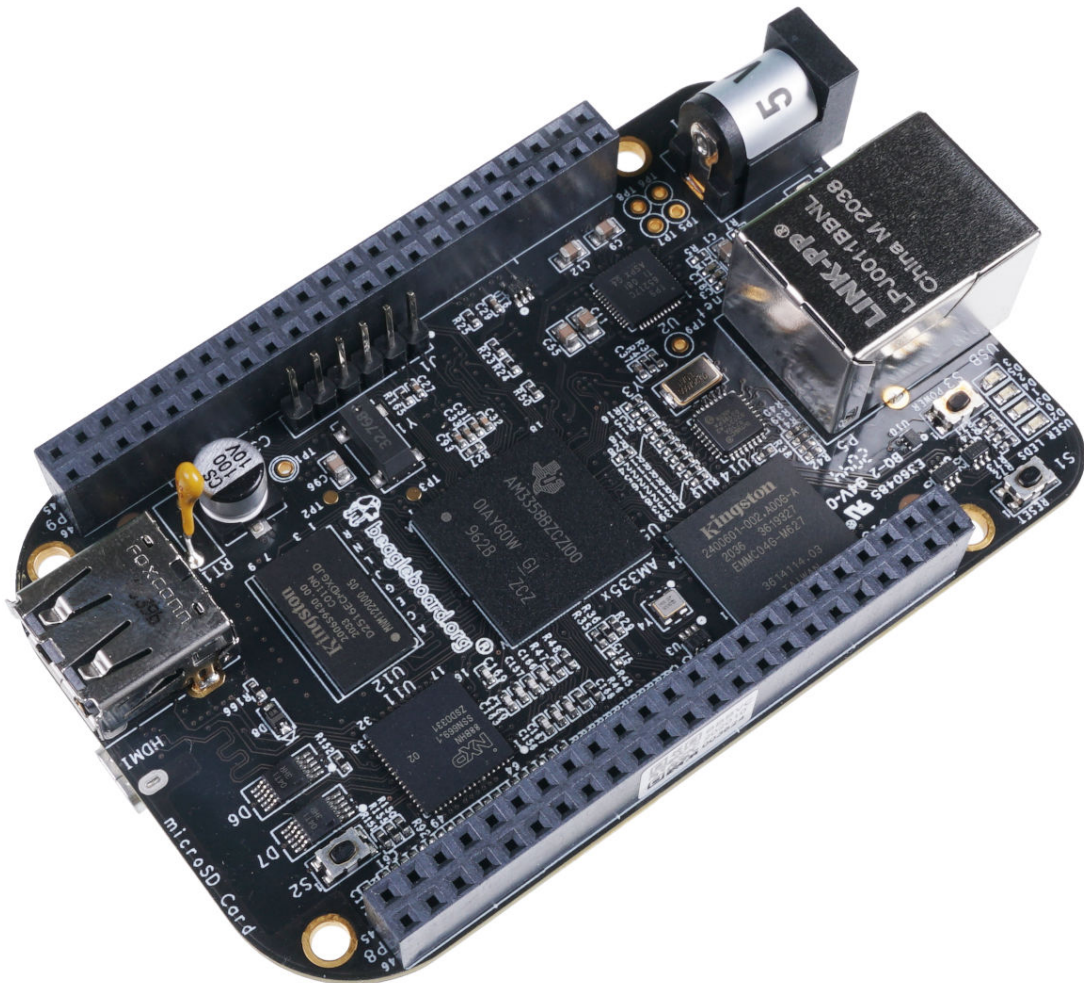

Fig. 10.3: 45 Degree Top

Chapter 11

Support Information

All support for BeagleBone Black design is through BeagleBoard.org community at BeagleBoard.org forum.

11.1 Hardware Design

Design documentation can be found on the eMMC of the board under the documents/hardware directory when connected using the USB cable. Provided there is:

- Schematic in PDF
- Schematic in OrCAD (Cadence Design Entry CIS 16.3)
- PCB Gerber
- PCB Layout (Allegro)
- Bill of Material
- System Reference Manual (This document).

This directory is not always kept up to date in every SW release due to the frequency of changes of the SW. The best solution is to download the files from <http://www.beagleboard.org/distros>

We do not track SW revision of what is in the eMMC. SW is tracked separately from the HW due to the frequency of changes which would require massive relabeling of boards due to the frequent SW changes. You should always use the latest SW revision.

To see what SW revision is loaded into the eMMC follow the instructions at https://elinux.org/Beagleboard:Updating_The_Software#Checking_The_Angstrom_Image_Version

11.2 Software Updates

It is a good idea to always use the latest software. Instructions for how to update your software to the latest version can be found at:

http://elinux.org/BeagleBoneBlack#Updating_the_eMMC_Software

11.3 Production board boot media

- BeagleBone Black Rev C3a

11.4 RMA Support

If you feel your board is defective or has issues, request an RMA by filling out the form at <http://beagleboard.org/support/rma>. You will need the serial number and revision of the board. The serial numbers and revisions keep moving. Different boards can have different locations depending on when they were made. The following figures show the three locations of the serial and revision number.

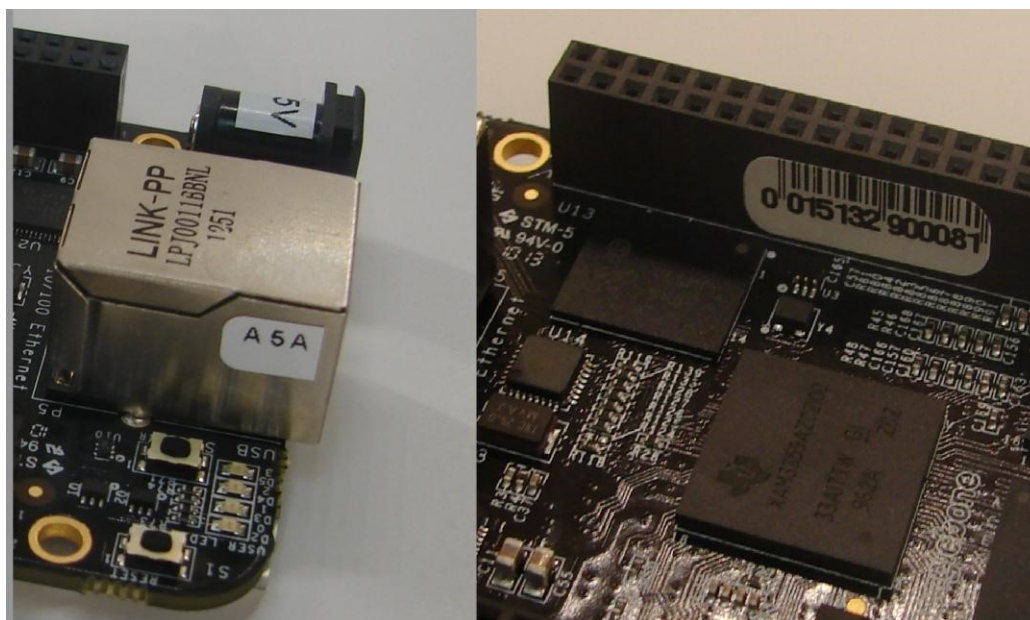

Fig. 11.1: Initial Serial Number and Revision Locations

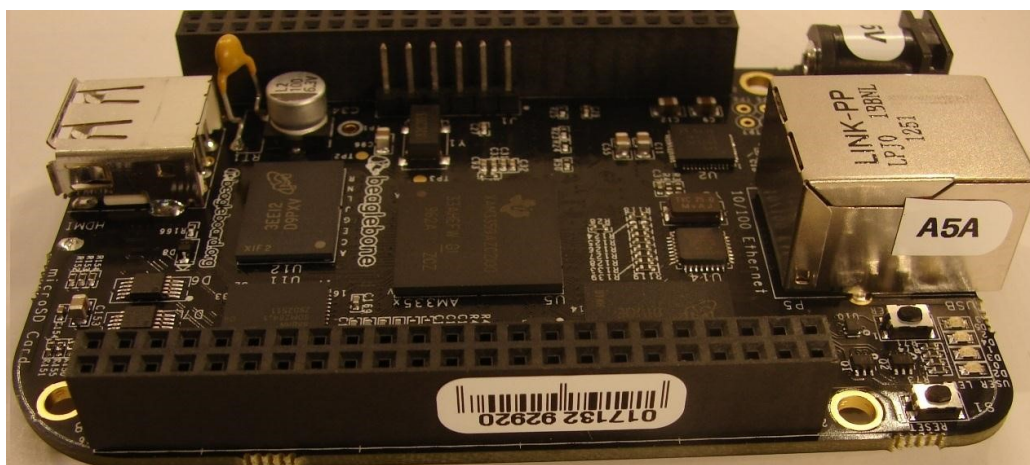

Fig. 11.2: Second Phase Serial Number and Revision Location

11.5 Trouble Shooting HDMI Issues

Many people are having issues with getting HDMI to work on their TV/Display. Unfortunately, we do not have the resources to buy all the TVs and Monitors on the market today nor go to eBay and buy all of the TVs and monitors made over the last five years to thoroughly test each and every one. We are depending on community members to help us get these tested and information provided on how to get them to work.

One would think that if it worked on a lot of different TVs and monitors it would work on most if not all of them, assuming they meet the specification. However, there are other issues that could also result in these various



Fig. 11.3: Third Phase Serial Number and Revision Location

TVs and monitors not working. The intent is that this page will be useful in navigating some of these issues. As others also find solutions, as long as we know about them, they will be added here as well. For access to the most up to date troubleshooting capabilities, go to the support wiki at http://www.elinux.org/Beagleboard:BeagleBoneBlack_HDMI

The early release of the Software had some issues in the HDMI driver. Be sure and use the latest SW to take advantage of the improvements.

http://www.elinux.org/Beagleboard:BeagleBoneBlack#Software_Resources

11.5.1 EDID

EDID is the way the board requests information from the display and determines all the resolutions that it can support. The driver on the board will then look at these timings and find the highest resolution that is compatible with the board and uses that resolution for the display. For more information on EDID, you can take a look at http://en.wikipedia.org/wiki/Extended_display_identification_data

If the board is not able to read the EDID, for whatever reason, it does not have this information. A few possible reasons for this are:

- Bad cable
- Cable not plugged in all the way on both ends
- Display not powered on. (It should still work powered off, but some displays do not).

11.5.2 DISPLAY SOURCE SELECTION

One easy thing to overlook is that you need to select the display source that matches the port you are using on the TV. Some displays may auto select, so you may need to disconnect the other inputs until you are sure the display works with the board.

11.5.3 OUT OF SEQUENCE

Sometimes the display and the board can get confused. One way to prevent this is after everything is cabled up and running, you can power cycle the display, with the board still running. You can also try resetting the board and let it reboot to resync with the TV.

11.5.4 OVERSCAN

Some displays use what is called overscan. This can be seen in TVs and not so much on Monitors. It causes the image to be missing on the edges, such that you cannot see them displayed. Some higher end displays allow you to disable overscan.

Most TVs have a mode that allows you to adjust the image. These are options like Normal, Wide, Zoom, or Fit. Normal seems to be the best option as it does not chop of the edges. The other ones will crop of the edges.

11.5.5 Taking a Nap

In some cases the board can come up in a power down/screen save mode. No display will be present. This is due to the board believing that it is asleep. To come out of this, you will need to hit the keyboard or move the mouse.

Once working, the board will time out and go back to sleep again. This can cause the display to go into a power down mode as well. You may need to turn the display back on again. Sometimes, it may take a minute or so for the display to catch up and show the image.

11.5.6 AUDIO

Audio will only work on TV resolutions. This is due to the way the specification was written. Some displays have built in speakers and others require external. Make sure you have a TV resolution and speakers are connected if they are not built in. The SW should default to a TV resolution giving audio support. The HDMI driver should default to the highest audio supported resolution.

11.5.7 Getting Help

If you need some up to date troubleshooting techniques, we have a Wiki set up at http://elinux.org/Beagleboard:BeagleBoneBlack_HDMI